

Analysis of Circular Elevated Service Reservoir Using STAAD Pro by Considering the Effect of Continuity

Priyanka M. Mankar¹; H.R. Nikhade²; Er. Minal Dehadrai³; Khalid Ansari⁴

¹Mtech Student, Department of Civil Engineering, Yeshwantrao Chavan College of Engineering, Nagpur, India.

²Assistant Professor, Department of Civil Engineering, Yeshwantrao Chavan College of Engineering, Nagpur, India.

³Engineer, M/s Structural Consultants. Khare Town, Dharampeth Nagpur, India.

⁴Assistant Professor, Department of Civil Engineering, Yeshwantrao Chavan College of Engineering, Nagpur, India.

Abstract

In most regions of the country, early damage of elevated water tanks during their service life is becoming an increasing concern. The majority of damage occurs in tanks due to a lack of knowledge in design and ignoring continuity effect. Elevated water tank are used for storage of water at certain height and supplying water for essential usage. Hence damage of such structure endanger supply of drinking water and severe economical losses. The main purpose of this research is to determine the importance of continuity analysis in practical application and use of staadpro software to analyse an elevated circular water tank. The bottom joint of water tank is examined using continuity effect. This is the common joint where base slab, wall, bottom rings beam, gallery, column and base beam join. water tank is subjected to self-weight and hydrostatic Pressure due to water. Continuity effect increase stress, Hoop tension, BM hence its necessary to consider its effect while designing the tank. The results obtained from staadpro software is nearly same with manual result. This indicated that staadpro is suitable for design and analysis of water tanks. Three model having capacity of 55 m³, 125 m³ and 221 m³ situated in yavatmal, buldana and ramtek district is taken for analysis. Seismic analysis and wind analysis is also carried out on this model for safety purpose.

Key-words: Elevated Service Reservoir, STAAD Pro v8i, Continuity Analysis, Seismic Analysis, Wind Analysis, Hoop Tension, Stresses.

1. Introduction

For the sustainability of life, water is just as important as food and air. The overhead tanks, which have always been an essential part of the water supply system, are important public utility and industrial structures that allow the required water head to be easily achieved and water to be made

available to all via gravity alone. Elevated tanks are provided by staging, which may include masonry walls and braced R.C.C. columns. Water pressure is applied to the walls. Water and tank loads must be supported by the base and transported by the staging. The staging is also designed to withstand wind forces. Tanks are designed in accordance with Indian standard code specifications and classified as underground, Ground supported, and elevated depending upon their position. They are also divided according to shape as circular, Rectangular, Spherical, and Intze tanks. Water tanks are usually only studied and designed for membrane stresses induced by minor flexural stresses. The moment of bending at the support is very poor due to the stiffness. In a tank with a large size, at the intersection of different elements Secondary stresses are emerging as a result of the continuity effect. When it comes to the construction of water retention systems, the strength is always kept more than sufficient. The continuity effect alters the near-joint hoop stresses and adds meridional moments, but not the meridional stresses, which remain unchanged from the state of the membrane. The effect of continuity are only temporary, and their effects will fade away quickly. Only membrane stresses exist in the interior of the members. In this study the effect of continuity is considered for examining the three different capacity ESR, and the result is compared to the staadpro result.

As per the research done by Himanshu Dwivedi and Dr.M.K. Gupta [1] A proportional increase in capacity would be not always result in a proportional rise in any of the necessary materials and by using three different circular water tanks of different dimensions for the same capacity the cost of the structure can be reduced. Hocine Hammoum et.al. [2] investigated that the Stability of the reservoir under the wind action depending upon the topography of the site. They also conclude that for a mountainous site, the failure probability exceeds the admissible value for all the wind zones. characteristic strength of concrete and wind speed is the important factors for considering the stability of elevated water tanks. Kamila Kotrasová [3] Study the wall of tank subjected to the hydrodynamic pressure with the help of finite element method. Also find out the response of concrete in dynamic time history using ADINA software. Kalyan Kumar Mandal et.al. [4] concluded that when the excitation frequency is less than the fundamental frequency increases the hydrodynamic pressure at the considerable amount. This hydrodynamic pressure similar to the linear pressure due to the seismic excitation. Kulvendra Patel concluded that [5] design of water tank is a time-consuming process specially in construction of an elevated cylindrical water tank which include a numerous mathematical formulae and calculations. It also takes a lot of time. Consequently Staad – pro has an immediate shear value based on the report. Mahmoud Abo-Elkhier et.al [6] investigated the failure of storage tanks which stored toluene having different capacities. The finding of their investigation allow to redesigned the tank according to API 650 and also make the recommendation for toluene

storage tank. Concluded that vapour pressure can be decreases that causes failure of tank by increasing the tank diameter. According to Mr. Manoj Nallanathel et.al. [7] Circular tanks has less corner stresses, maximum shear, bending stresses than other tanks. The use of Staad pro in design produces more reliable shear force and bending moment results than the more convenient process. Neha. S. Vanjari et.al. [8] Designed circular intze water tank by membrane analysis without considering the effect of continuity. They concluded that manual design of water tank is very difficult job and by considering continuity it makes more complicated. For large capacity intze tank is more economical as it required less reinforcement. Prof. Patel Nikunjir and Prof. Jugal Mistry [9] Concluded that the use of a bracing system will help to minimize deflection. Deflection is also affected by slab thickness. By placing a heavy column at the bottom of the water tank, the stability can be increased. The midpoint of the top portion receives the more stress. According to the Pedro A. Calderón et.al [10] Special care should be taken while lying of foundation which are the reason of failure. Leaks can increase the uplift pressure on the wall and comprising the stability of water tanks. Sagar Mhamunkar et.al. [11] Designed Elevated Circular Water Tank using Limit state method with reference to IS 3370(2009) and Is 456:2000 by limiting the stresses in steel and cracking width so that the concrete is not over stressed and concluded that limit stress method is most economical than the working stress method in case of steel and concrete quantity. Mr. Sandip L Gongale et.al. [12] analysed various reinforced elevated water tank having 400 m³ capacity by considering both the effect of wind and seismic and suggest the suitable design of water tank which having the minimum deflection. They concluded that according to element properties, the most cost-effective water tank is a square water tank, but an appropriate design for Intz Water Tank is recommended based on the study. Valentino Sangiorgio et.al. [13] analysed the failure of reinforced concrete water tank and study 32 cases to demonstrated performance and degradation level of water tank. Insufficient strength of the concrete and the thickness of the concrete cover are the main reason for the failure of tanks. Y. Wang et.al. [14] Experimentally study the response of stainless steel under the impulsive loading also the blast loading which causes deformation of water tank. Thickness of plate in rear and front is different. Plates are deformed together to absorbed blast energy.

2. Experimental and Research Methodology

Most of the analysis on the water tank is carried out by membrane analysis without considering the effect of continuity because it makes the analysis complicated. In this paper, the water tank is analyse by considering the effect of continuity, and the same model is also analysed with the

help of staadpro software. Model taken for analysis is 55,000 litre capacity rccsr of 8 m stg ht and 4 columns for wagholi villages tal – kelapur, dist – yavatmal, 1.25 lakh lit capacity rccsr of 9m stg ht for tal-sindkhed raja, dist-buldana, 2.21 lakh lit capacity rccsr of 18 m stg ht situated in ramtek. Continuity changes the near joint Hoop Tension and the reinforcement. Therefore, when water tanks are designed without considering their effect damage may occur. The manual calculation for analysis is taken from Plain and reinforced, Vol I& II Jain and Jaikrishna book. Three Models of ESR having different capacities, different numbers, and arrangements of columns are analysed manually and in Staadpro. Effect occurring at the joint node where cylindrical wall, Base slab, gallery, and column meet also finds out by Staadpro. As the Limit state method is used in analysis which gives less area for reinforcement crack width calculation is also done. Seismic Forces and Wind Forces acting on staging are calculated for the stability of the water tank during an earthquake.

3. Analysis of ESR

Three model of circular ESR having capacity of 55 m³, 125 m³, and 221 m³, staging height of 8 m, 9 mand 18 m are taken for analysis. SBC of soil is 10 t/m² and 15 t/m². Plan of ESR at staging is shown in fig 1. The geometric properties of Circular ESR are given in Table 1. Sizes of various components of water tank are mentioned in Table 2. In the first model diameter of column is 400mm, 4 in number whereas the second model is having 4 number of periphery and one interior column, both are 450 mm diameter. The third model having 8nos of periphery column and one interior column. The diameter of column in the Third model is 400 mm. The main purpose of this analysis is to understand the continuity effect on the water tank and checking the suitability of staadpro software in analysis of tanks.

Is 3370 is used for the design of ESR. The roof slab is supported on the wall which is circular and subjected to live load, floor finish, and self-weight. The base slab is similar to the square slab supported on the beam. According to IS 3370, the base slab must have a crack width of less than 0.2 mm. Therefore Crack width calculation is also done for the base slab. The base beam is design in such a way that it should carry load from the base slab without failure. Stresses in the Base beam should be kept less than the allowable stresses of 20 kg/cm². Design of Cylindrical wall is carried out by considering hoop tension and bending moment acting on it due to the water load. Continuity analysis of bottom joint is also carried out by considering the stiffness of member meeting at a point. Moment stiffness, corresponding thrust, thrust stiffness obtained after analysis of bottom joint of wall

in 55 m³ tank is 0.002462mm, 0.004546mm and 0.0167885mm, in 125 m³ ESR is 0.002166 mm, 0.003520 mm, and 0.01144 mm, in 221 m³ ESR is 0.00175 mm, 0.00232 mm and 0.006124 mm.

Fig. 1 - (a) 55 m³ Capacity ESR having 4nos of Columns; (b) 125 m³ Capacity ESR having 5nos of Columns; (c) 221 m³ Capacity ESR having 9 no's of Columns

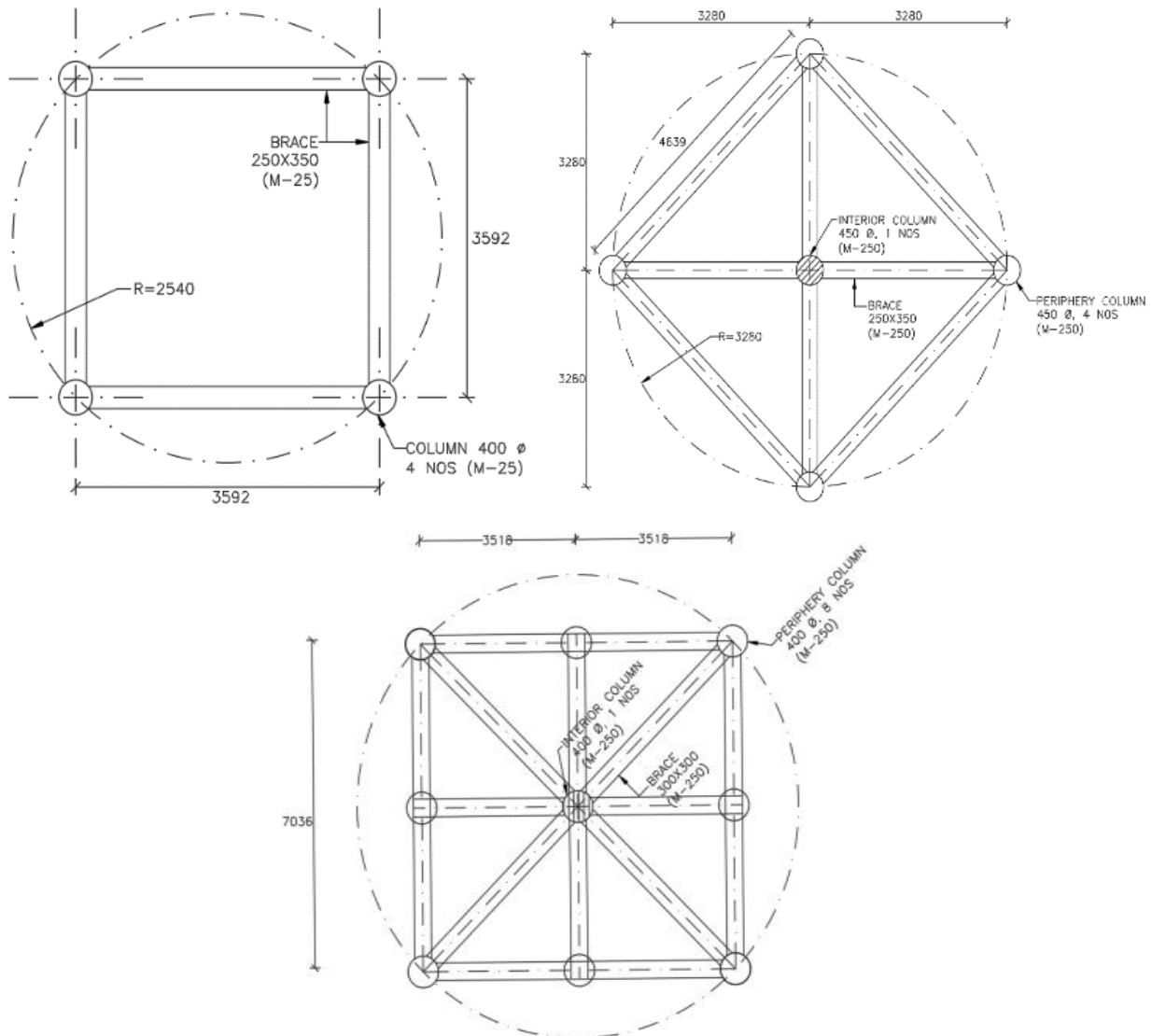

Staging which comprises columns and braces is designed for the critical combination of Dead load, Live load acting vertically download, and lateral forces of critical Seismic force or Wind forces. Seismic Forces are calculated as per IS 1893, considering seismic Zone of III with zone factor "Z" =0.16, Importance factor "I" = 1.5, Response Reduction factor "R" =4 as per IS 1893. As the capacity of ESR is less than 1000 cum (10 Lakh litres) full water mass is considered as impulsive mass and system as Single Degree of Freedom (SDOF) as per Is 1893. Wind loads are calculated considering a Basic Wind speed of 44 m/s as per IS 875. Critical lateral force of either Seismic or wind loads is

considered. The column is designed for axial loads and Bending moments arrived as above as per SP 16 Confining reinforcement near column brace joint is provided as per IS 13920. The braces are designed for moments and shear due to lateral force and self-weight. The foundation is provided as raft foundation to be on the conservative side and dimensioned as per the forces and SBC of the soil given as per the geotechnical report of the site.

Table 1 - Geometrical Properties of Circular ESR

Capacity	FSL	LDL	GL	FL	Free Board	SBC of Soil	Seismic Zone
55 m ³	11 m	8 m	0 m	-3 m	0.3 m	10 t/m ²	III
125 m ³	13 m	9 m	0 m	-3 m	0.3 m	15 t/m ²	III
221 m ³	21 m	18 m	0 m	-3.5 m	0.3 m	10 t/m ²	III

Table 2 - Sizes of various Components of Water Tank

Component	Roof Slab	Cylindrical Wall	Base Slab	Gallery	Base Beam	Braces	Columns
Size (mm)	120 thk	200 thk	200 thk	120 thk	300x500 mm	250x 350	400 dia 4 nos
Size (mm)	120 thk	200 thk	200 thk	120 thk	300x500 mm	250x 350	450 dia 5 nos
Size (mm)	120 thk	200 thk	200 thk	120 thk	300x600 mm	300x300	400 dia 9 nos

Analysis of bottom joint of wall, base slab, bottom ring beam and gallery for all model is carried out by considering the effect of continuity. Slope in 55 m³, 125 m³, and 221 m³ capacity ESR is 0.000667 m. Displacement in 1st, 2nd and 3rd model is 1.84m, 1.624 m, 1.3193 m. From this calculated value it is clear that 55 m³ capacity ESR is having higher displacement than 125 m³ and 221 m³ ESR. The value of Hoop Tension and Bending moment in wall and base slab is shown in Table 3. HT in the base slab is higher than Wall, BM is same for both the components.

Table 3 - Hoop Tension and Bending Moments

Capacity	HT in-wall (kg)	HT in B Slab	BM in Wall (kgm)	BM in B Slab
55 m ³	1172.281671	1941.910072	20.65421269	-20.6542127
125 m ³	2345.932177	3578.910483	22.4429	-22.4429
221 m ³	3459.44	4831.07	10.73	-10.73

Modelling of water tank is taken place in staadpro. Plates are used to design the geometry of wall, base slab, roof slab, and gallery. The model of staadpro is shown in fig. 2. Rendering View is shown in fig.3. Fixed support is applied to columns. Dead load, live load, and water load are applied to the tank. Load combination of the DL, LL, and water load is also applied. The roof slab is subjected to DL of 300 kg/m². Waterproofing of 100 kg/m² and LL of 75 kg/m². DL and LL of 300

kg/m² are applied to the gallery. Water load of 3300 kg/m², Plaster load of 42 kg/m², DL of 500 kg/m² are applied to the base slab.

Fig. 2 - (a) StaadPro Model of 55 m³ Capacity ESR; (b) StaadPro Model of 125 m³ Capacity ESR; (c) StaadPro Model of 221 m³ Capacity ESR

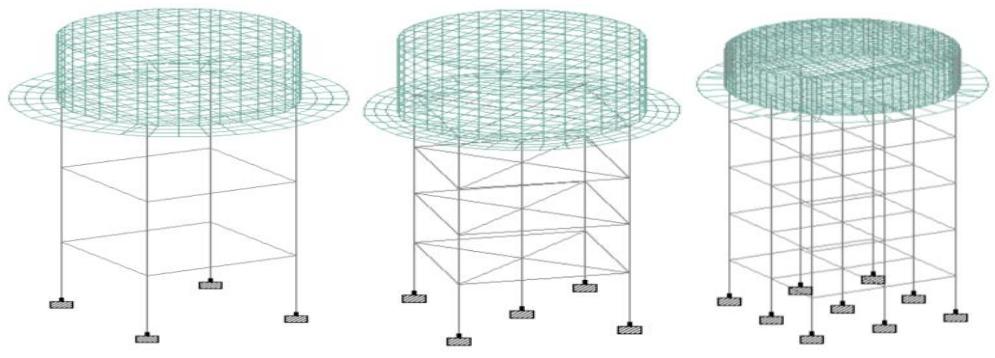
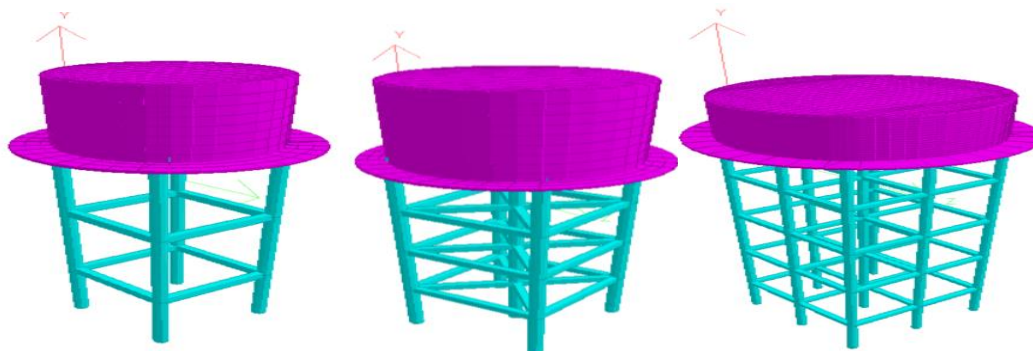

Fig. 3 - (a) Rendering View of 55 m³ Capacity ESR; (b) Rendering View of 125 m³ Capacity ESR; (c) Rendering View of 221 m³ Capacity ESR



Hoop Tension and Bending moment in wall, base slab is also calculated from staad result output by multiplying the plate stresses with the thickness of corresponding members. Its value is shown in table 4.

Table 4 - Hoop Tension and Bending Moments obtained from Staad Result

Capacity	HT in the wall (kg)	HT in B Slab	BM in-wall (kgm)	BM in B Slab
55 m ³	1064	1844	20.78	21.99
125 m ³	2245	3479	21.9	21.6
221 m ³	3100	4911	11.22	10.99

4. Result and Discussion

Hoop Tension at various points with increasing height in the cylindrical wall of elevated circular water tank having capacity of 55 m³ and 125 m³ is shown in fig 4. From the value obtained it is found that HT in wall near the base slab is higher than the roof slab due to the continuity effect i.e

HT is directly proportional to height. Height of 125 m³ capacity ESR is 4.3 m hence 18 points are considered for calculating HT. 10 points are considered for 55 m³ capacity ESR having height of 3.3 m. Area of steel (As) is also calculated. HT in wall for 55 m³ ESR is 0 kg, 805.2 kg, 1610.4 kg, 2415.6 kg, 3220.8 kg, 4026 kg, 4831.2 kg, 5636.4 kg, 6441.6 kg and 7246.8 kg at height of 3.3 m, 2.97 m, 2.64 m, 2.31 m, 1.98 m, 1.65 m, 1.32 m, 0.99 m, 0.66 m, and 0.33 m. And area of steel is 536.8 mm², 1073 mm², 1610.4 mm², 2147.2 mm², 2684 mm², 3220.8 mm², 3757.6 mm², 4294.4 mm², 4831.2 mm². Similarly, In 125 m³ESR the value of HT is 0 kg, 790 kg, 1580 kg, 2370 kg, 3160 kg, 3950 kg, 4740 kg, 5530 kg, 6320 kg, 7110 kg, 7900 kg, 8690 kg, 9480 kg, 10270 kg, 11060 kg, 11850 kg, 12640 kg and 13430 kg at height of 4.3 m, 4.05 m, 3.8 m, 3.55 m, 3.3 m, 3.05 m, 2.8 m, 2.55 m, 2.3 m, 2.05 m, 1.8 m, 1.55 m, 1.3 m, 1.05 m, 0.8 m, 0.55 m, 0.3 m, 0.05 m. From the above value obtained it is clear that Hoop Tension in the wall increases as we go closer to the Base slab and away from the roof slab due to the effect of continuity.

Fig. 4 - Hoop Tension in the Wall at Increasing Height (a) for 55 m³ ESR; (b) for 125 m³ ESR

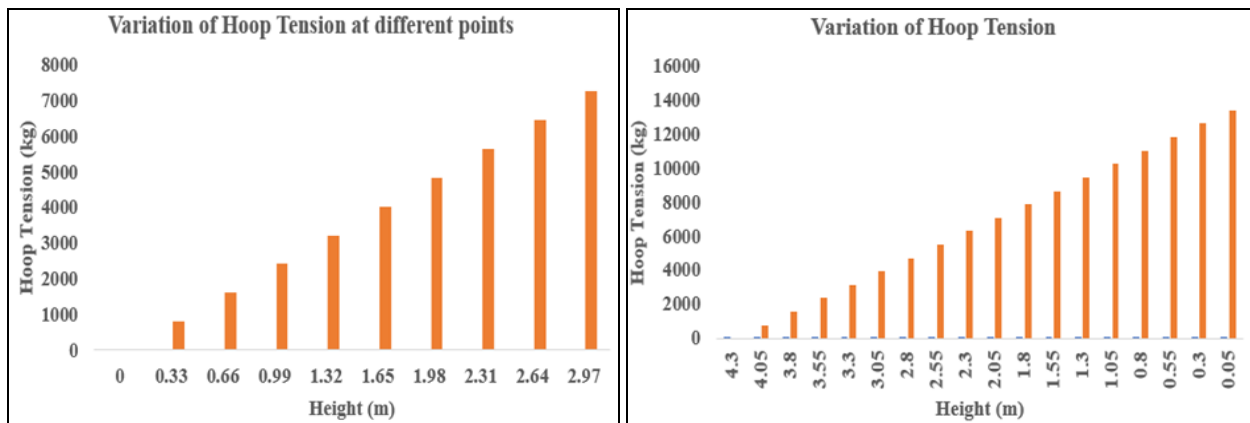

4.1. Comparative Study of Bending Moment and Hoop Tension in the wall by Continuity Analysis and Staadpro Analysis

Variation of Bending Moment in wall by manual calculation considering the effect of continuity and by staadpro result is shown in fig 5(a). There is no such great difference in both the value. The value of BM in wall of 55 m³, 125 m³ and 221 m³ capacity ESR obtained from the manual calculation is 20.65 kg-m, 22.44 kg-m, and 10.73 kg-m. from staad result, its value is 20.78kg-m, 21.9 kg-m and 11.22 kg-m. Fig 5 (b) shows the difference in the value of hoop tension obtained by manual calculation and staadpro result. HT in wall of 55 m³, 125 m³, and 221 m³ capacity ESR is 1064 kg, 2245 kg, and 3100 kg obtained from staadpro software and 1172.28 kg, 2345.93 kg, 3459.44 kg obtained from manual calculation.

Fig. 5 - (a) Bending Moment in the Wall with the Effect of Continuity; (b) Hoop Tension in the Wall with the Effect of Continuity

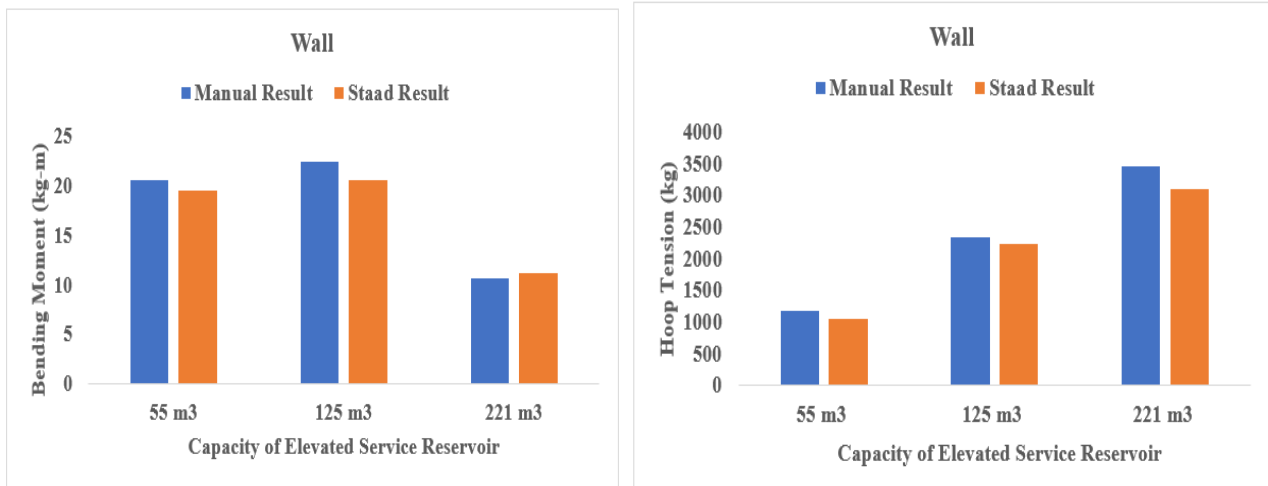

4.2. Comparative Study of Bending Moment and Hoop Tension in Base Slab by Continuity Analysis and Staadpro analysis

BM and Hoop tension in base slab is shown in fig (6). BM in base slab of 55 m³, 125 m³ and 221 m³ capacity ESR is 20.9 kg-m, 21.6 kg-m and 10.79 kg-m obtained by manual calculation with considering the effect of continuity. From staad results, its value is 22.45 kg-m, 22.44 kg-m and 10.79 kg-m. HT in Base Slab of 55 m³, 125 m³, and 221 m³ capacity ESR is 1844 kg, 3479 kg and 4911 kg obtained staadpro software and 1941.91 kg, 3578.91 kg, 4831.07 kg obtained from manual calculation.

Fig. 6 - (a) Bending Moment in Base Slab with the Effect of Continuity; (b) Hoop Tension in Base Slab with the Effect of Continuity

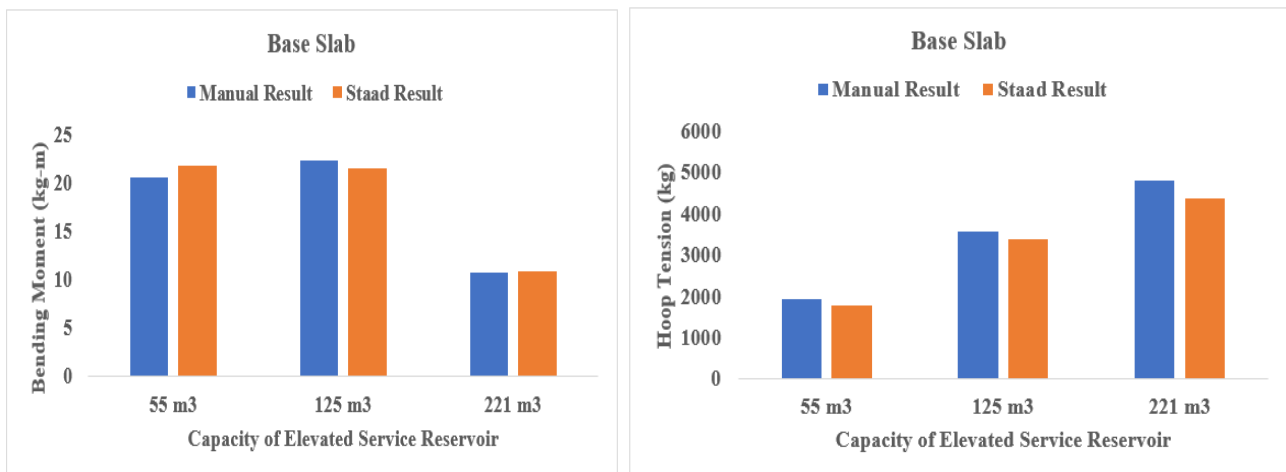

4.3. Seismic and Wind Analysis of ESR for Tank Full and Tank Empty Condition

IS 1893 is used for seismic analysis of ESR. This analysis is carried out for tank full and tank empty conditions shown in fig 7. Critical damping is taken as 5 %. Seismic Zone is III and the soil type is soft. The seismic zone factor is 0.16. The important factor is 1.5. The response reduction factor is 4. As the capacity of ESR is less than 1000 cum (10 Lakh litres) full water mass is considered as impulsive mass and system as Single Degree of Freedom (SDOF) as per Is 1893. Design horizontal seismic coefficient is 0.039261. Seismic force of 4803 kg, 10154 kg and 8884 kg for tank full condition is obtained for 8 m, 9 m, and 18 m staging height ESR. Similarly, Seismic force of 3408 kg, 6890 kg and 5958 kg is obtained for tank empty condition.

Fig. 7 - Seismic Analysis of Circular Elevated Service Reservoir for Tank Full and Tank Empty Condition

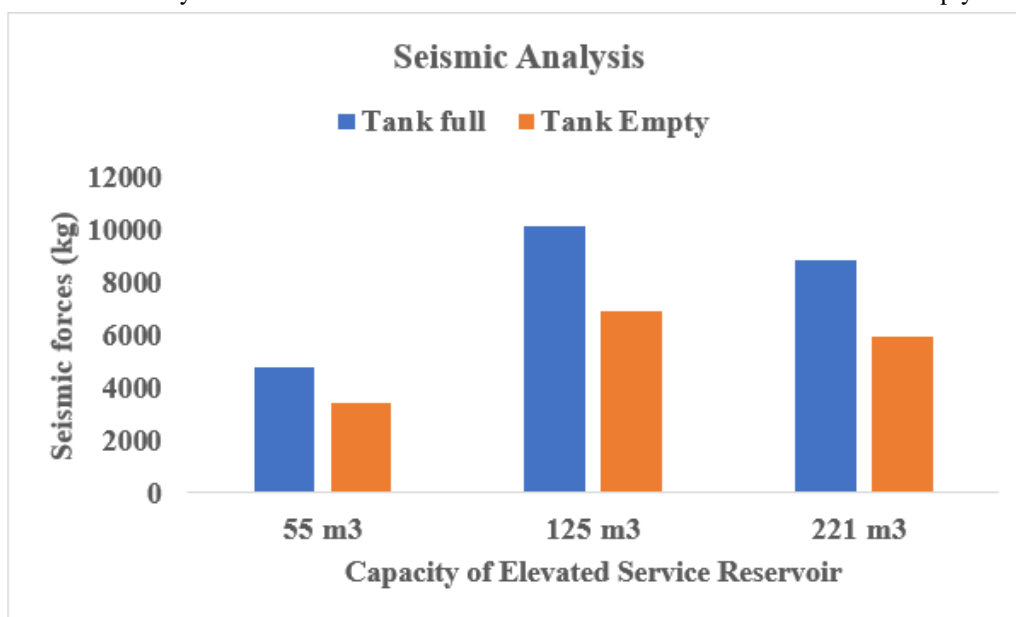

Wind analysis on ESR is shown in fig 8. IS 875/1987, part III is used for analysis. Basic wind pressure is taken as 44m/sec. The probability factor or risk factor k_1 is 1. Terrain height and structure size factor for Class A, Category 3 is 0.912 and 0.926 for height 10.144 m and 11.300. Topography Factor is 1. Design wind speed for 55 m³ and 125 m³ ESR is 40.12 m/sec and 221 m³ ESR is 40.73 m/sec. Wind force of 1774kg, 2785 kg 4053.7 kg acting on the container and 1045kg, 1716 kg, 6700 kg acting on the column of 1st, 2nd and 3rd model. The total wind forces acting at the top is 2444 kg, 4363 kg and 8357 kg.

Fig. 8 - Wind Analysis of Circular Elevated Service Reservoir on Container and Column

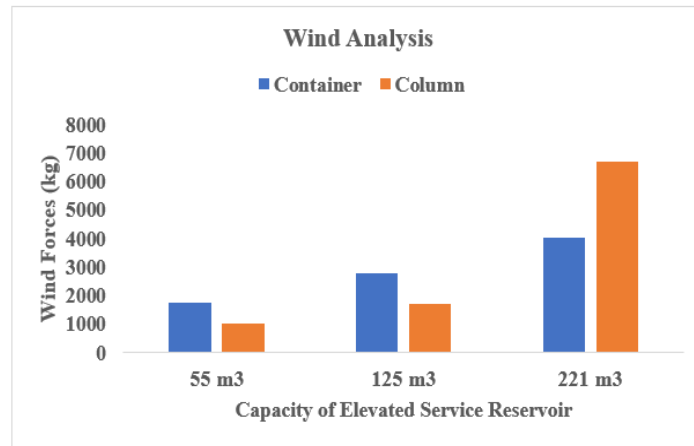

Designing and analysis of circular water tank in staad pro v8i produces more reliable shear force and bending moment results than the manual calculation. Corner stresses and bending stresses in wall is less as compared to joint stresses. limit stress method is most economical than the working stress method in case of steel and concrete quantity. Hence cracking width check is done so that the concrete is not over stressed. 55 m³, 125 m³ and 221 m³ capacity ESR having cracking width of 0.2 mm hence safe for cracking.

5. Conclusion

Analysis of circular elevated service reservoir by considering the effect of continuity is carried out in this paper for three different capacity. The same model is also analysed with the help of Staadpro software.

- 1) In the 1st model of 55 m³ capacity ESR, the value of Hoop Tension changes from 805.2 kg to 7248.8 kg for a height of 3.3 m to 0.33 m.
- 2) In the 2nd model of 125 m³ capacity Hoop Tension changes from 790 kg to 13430 kg for a height of 4.05 m to 0.05 m, and 0.05 m is the height closer to the base slab.
- 3) It is observed that the Continuity effect increase near joint Hoop Tension due to the stiffness of members such as a wall, base slab, bottom ring beam, and gallery meeting the point.
- 4) It is observed that Stresses in wall for 55 m³, 125 m³ and 221 m³ capacity varying between 0.0119 N/mm² to 0.0520 N/mm², 0.0477 N/mm² to 0.8008 N/mm², and 0.0680 N/mm² to 1.81004 N/mm².

- 5) From the stress diagram, it is observed that the value of stresses and Hoop Tension near the base slab is higher than the roof slab.
- 6) The horizontal seismic force for the seismic zone III when the tank in full condition for the capacity of 55 m³, 125 m³, and 221 m³ is 4803 kg, 10154 kg, and 8884 kg.
- 7) The horizontal seismic force for the seismic zone III when the tank in Empty condition for the capacity of 55 m³, 125 m³, and 221 m³ is 3408 kg, 6890 kg, and 5958 kg.
- 8) Total wind forces for a basic wind speed of 44 m/sec for the capacity of 55 m³, 125 m³, and 221 m³ are 2444 kg, 4363 kg, and 8357 kg.

Designing of water tank after analysis of bottom joint and checking crack width criteria increases the strength, stability and life of water tanks. Staad pro v8iis suitable for designing and analysis of circular water tanks but direct values of different parameters are not found in software.

References

- Himanshu Dwivedi, Dr.M.K. Gupta, "Analysis and design of water tank employing staad. Pro for cost optimization," *International Journal of Scientific Research and Engineering Development*, 2(4), 2019.
- Hocine Hammouma, Karima Bouzelhaa, Youcef Sellamb, Lounes Haddadb, "Structural reliability of elevated water reservoirs under wind loading," *Procedia Structural Integrity*, Vol. 22, 235-242, 2019.
- Kamila Kotrasová, "Study of hydrodynamic pressure on wall of tank," *Procedia Engineering* 190(2017) 2-6.
- Kalyan Kumar Mandal n, DamodarMaity, "Nonlinear finite element analysis of water in rectangular tank," *Ocean Engineering* 121 (2016) 592-601.
- Kulvendra Patel, "Wind and seismic analysis of elevated tank using staad pro," *International Research Journal of Engineering and Technology*, 5(10), 2018.
- Mahmoud Abo-Elkhier, Kamel Muhammad, "Failure analysis of an exploded large-capacity liquid storage tank using finite element analysis," *Engineering Failure Analysis* 110 (2020) 104401.
- Mr. Manoj Nallanathel, Mr. B. Ramesh, L. Jagadeesh, "Design and anlysis of water tanks using staad pro," *International Journal of Pure and Applied Mathematics*, 119(17), 3021-3029, 2018.
- Neha. S. Vanjari, krutika. M. Sawant, Prashant S. Sisodiya, S.B. Patil, "Design of Circular Overhead Water Tank," *International Journal of Engineering Research in Mechanical and Civil Engineering*, 2(7), 2017.
- Prof. Patel Nikunj, prof. Jugal Mistry, "Analysis of circular water tank stresses under hydrostatic loading by using stadd pro software," *Indian Journal of Research*, 5(9), September 2016.
- Pedro A. Calderón, Jose M. Adam, Ignacio Payá-Zaforteza, "Failure analysis and remedial measures applied to a RC water tank," *Engineering Failure Analysis* 16 (2009) 1674-1685.

Sagar Mhamunkar, Mayur Satkar, Dipesh Pulaskar, Nikhil Khairnar, Reetika Sharan, Reshma Shaikh, "Design and analysis of overhead water tank at phulenagar, Ambernath," *International Research Journal of Engineering and Technology*, Volume: 06, Issue: 04, 2018.

Mr. Sandip L Gongale, Mr. Mayur K Ghumde, "Analysis of elevated service reservoir by using commercial software," *International research journal of engineering and technology*, 3(12), 2016.

Valentino Sangiorgioa, Giuseppina Uvaa, Jose M. Adamb, Lucia Scarcellia, "Failure analysis of reinforced concrete elevated storage tanks," *Engineering Failure Analysis* 115(2020) 104637.

Y. Wang, S.C. Lee, "Experimental study of water tank under impulsive loading," *Archivers in civil and mechanical engineering*," 263.