

Extracting Maximum Power from Wind Turbine Using Tip Speed Ratio and PO Algorithms by Limiting the Wind Speed

K. Suja¹; Dr. T. Yuvaraj^{2*}

¹Research Scholar, Department of Energy and Environmental Engineering, Saveetha School of Engineering, Saveetha Institute of Medical and Technical Sciences, Saveetha University, Chennai, Tamilnadu, India.

¹sujaene@gmail.com

^{2*}Project Guide, Department of Electrical and Electronics Engineering, Saveetha School of Engineering, Saveetha Institute of Medical and Technical Sciences, Saveetha University, Chennai, Tamilnadu, India.

^{2*}yuvarajt.sse@saveetha.com

Abstract

Aim: This research is focused on obtaining the maximum power by controlling the speed of the wind turbine. **Materials and methods:** Innovative Tip speed ratio and PO algorithm are implemented for obtaining maximum power from the wind turbines. **Result:** By controlling the wind speed (1.9087rad/sec) we obtained maximum power output (200kW) from the wind turbine to increase its efficiency level. **Conclusion:** Tip speed ratio method (200kW) provides better power output compared to PO algorithm (192kW) for the selected data set.

Key-words: Innovative Tip Speed Ratio, PO Algorithm, Wind Turbine, Efficiency, Output Power, Artificial Intelligence.

1. Introduction

Wind energy availability is increasing in renewable energy sectors in day to day life. Energy is playing a vital role for countries' economic (Assareh and Biglari 2015) growth. It offers several advantages like less environmental impact and inexhaustible source (Ananth and Kumar 2016). The main aim of this research is to limit the speed of the wind turbine by using tip speed ratio method to obtain maximum power output. It can be implemented in rural areas.

In the last 5 years, more than 60 papers have been published on varying wind speed of turbines and extracting maximum power. The author improves the efficiency of MPPT-TSR using maximum power point tracking method to obtain maximum power from wind turbines (Ghiasi et al.

2021). Optimum values of TSR are different for every wind turbine system, so it can be implemented in MPPT controllers for future designs to obtain maximum efficiency ((Bilal and Liu 2018). The authors implemented aerofoil profiles which directly capture the ratio of wind power to improve the power performance of vertical axis wind turbine systems with the goal to achieve high power efficiency. (Ma et al. 2018). Tip speed ratio method is implemented to increase the production function of wind turbines ((Posa 2020). The authors maximized the output power generation of wind turbines by changing the speed of wind using MPPT methods. (Samokhvalov et al. 2020). Based on overall analysis, MPPT-TSR based wind speed control provides better results to get maximum power from wind turbines (Ghiasi et al. 2021).

Previously our team has a rich experience in working on various research projects across multiple disciplines (Sathish and Karthick 2020; Varghese, Ramesh, and Veeraiyan 2019; S. R. Samuel, Acharya, and Rao 2020; Venu, Raju, and Subramani 2019; M. S. Samuel et al. 2019; Venu, Subramani, and Raju 2019; Mehta et al. 2019; Sharma et al. 2019; Malli Sureshbabu et al. 2019; Krishnaswamy et al. 2020; Muthukrishnan et al. 2020; Gheena and Ezhilarasan 2019; Vignesh et al. 2019; Ke et al. 2019; Vijayakumar Jain et al. 2019; Jose, Ajitha, and Subbaiyan 2020). Now the growing trend in this area motivated us to pursue this project.

Control of wind turbines ensures the optimum performance, safe and stable by optimizing the wind output power. Many conventional methods have been implemented for controlling the wind turbine such as pitch, yaw, and rotational speed control. The existing methods have not extracted the maximum power from wind turbines efficiently and economically. In addition to that, limiting the wind speed has not been considered previously using tip speed ratio method to obtain maximum power from wind turbines. Hence tip speed ratio method has been taken to limit the wind speed to extract maximum power. In this paper, a comparison of two efficient wind speed control methods, TSR and PO have been implemented and analyzed.

2. Materials and Methods

This study was conducted in a power electronics lab at Saveetha School of Engineering. In this study, two numbers of groups are selected for comparing the process and their results. in each group, 7 sets of samples and 14 sample tests have been carried out. (g power setting parameters statistical test-difference between two independent means, $\alpha=0.05$, power-0.80, effect size-0.5, mean tsr- 0.76, mean po - 0.21, sd-0.029). Two methods were implemented namely Tip speed ratio and

PO algorithm to limit the wind speed for obtaining maximum power. The system is simulated using MATLAB© Simulink model version 2019a (P., C., and T. 2018).

Tip Speed Ratio Method

In this method, continuous feedback is taken from the wind generator and is compared with reference value (tip speed value). If any deviations the controller will take the corrective action. It optimizes the tip speed ratio value to regulate the speed of the wind turbine in order to obtain maximum energy from it. (Ochieng, Manyonge, and Oduor 2014). The block diagram of tip speed ratio method depicts in Fig. 1.

Fig. 1 - Block Diagram of Tip Speed Ratio

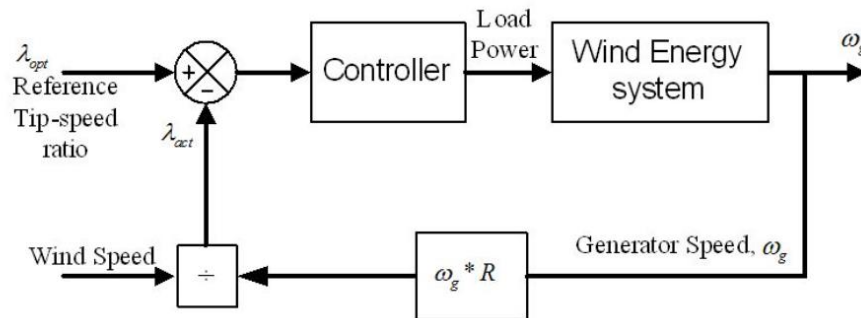

PO algorithm is the conventional control strategy which is used to regulate the turbine speed to optimise the power. The PO technique is predicated on shifting the wind speed by a step-size and monitoring the modification within the extracted power until the slope of (P – ω) curve becomes zero (Ali et al. 2020). The block diagram of PO algorithm based wind turbine control is shown in Fig. 2.

Fig. 2 - Block Diagram of PO Algorithm

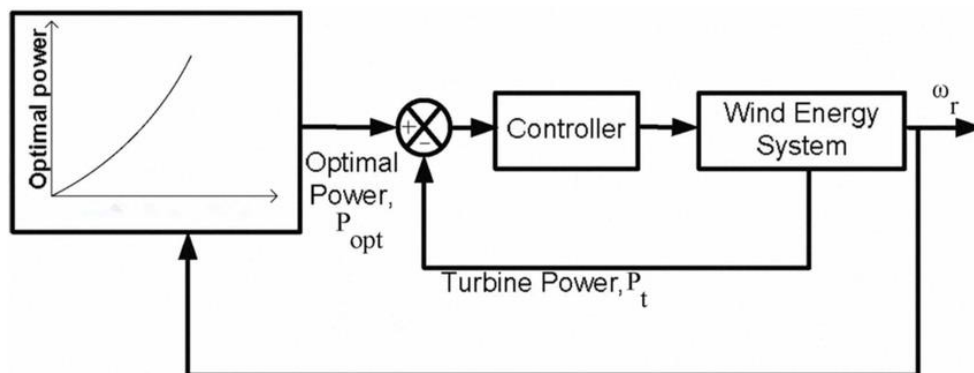

For testing the proposed system the Matlab© Simulink (2019a) software has been used and the results are determined with different wind speeds. The results are validated by changing the wind speed of the wind turbine to obtain maximum output power. The obtained results for various wind speeds have been tabulated and its output power is calculated for both the method and is tabulated in Table 1.

Table 1 - Comparison of tip speed ratio and po algorithm of power output as (200kW) and (192kW)

TIP SPEED RATIO		PO ALGORITHM	
Speed (Rad/Sec)	Maximum power (KW)	Speed (Rad/Sec)	Maximum power (KW)
1. 7593	155	1. 7593	144
1. 7216	159	1. 7216	150
1. 7467	172	1. 7467	165
1. 8216	180	1. 8216	177
1. 8721	190	1. 8721	182
1. 8921	196	1. 8921	190
1. 9087	200	1. 9087	192

Statistical Analysis

SPSS software is used for statistical analysis of TSR and PO algorithm based methods. The independent variable is wind turbine speed and the dependent variable is efficiency. Two independent group analysis tests are carried out to calculate the efficiency of the wind turbine for both methods.

3. Results

Fig. 3 - Comparison of TSR and PO methods

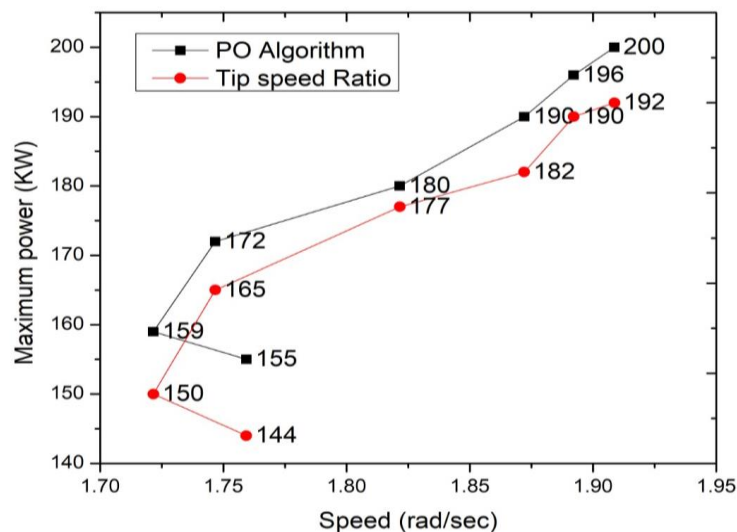

Table-1 results show that the control of wind turbines by using the TSR (200 kW) provides better output power than PO (192kW). Fig. 3 shows the comparison of output power and wind speed for TSR and PO methods. From Fig. 3 the black lines represent the wind output power of TSR and the red line represents the wind output power of PO. This ensures that the output power of wind turbine values are better using the TSR method.

Table 2 represents the Independent t test analysis using the SPSS system. T-test has been performed for tip speed ratio and PO algorithm by varying the wind speed between 100 to 3000 (rpm). TSR has a mean value of 1. 82 which is better than PO algorithm (Mean value: 0. 96). The maximum power extracted from wind turbines using TSR is 181. 14 (kW) and PO is 175. 29 (kW). The standard deviation of TSR is 0. 029 and PO is 0. 008. From the above discussions TSR based wind turbine control provides better results than PO.

Table 2 - T-test Comparison of TSR and PO

Group Statistics					
	Group	N	Mean	Std. Deviation	Std. Error Mean
Speed	1	7	1. 82	. 076	. 029
	2	7	. 96	. 021	. 008
Maximum power	1	7	181. 14	33. 078	12. 502
	2	7	175. 29	18. 328	6. 927

Table 3 - Independent sample T-test t is performed for the two groups for significance and standard error determination. P value is less than 0. 05 and it is considered to be statistically significant.

		Levene's Test for Equality of Variances		t-test for Equality of Means						
		F	Sig.	t	df	Sig. (2-tailed)	Mean Difference	Std. Error Difference	95% Confidence Interval of the Difference	
									Lower	upper
Speed	Equal variances assumed	15. 257	0. 002	28. 853	12	. 000	. 857	0. 030	0. 792	0. 921
	Equal variances not assumed			28. 853	6. 883	. 000	. 857	0. 030	0. 786	0. 927
Maximum power	Equal variances assumed	1. 623	0. 227	. 410	12	. 689	5. 857	14. 293	-25. 285	36. 999
	Equal variances not assumed			. 410	9. 367	. 691	5. 857	14. 293	-26. 284	37. 998

Table 3 depicts Independent samples test. There is a significant difference in output power between the two groups (TSR and PO) since $p < 0.05$ speed (t value is 28.858 and mean difference is 0.857) and maximum power (t value 0.410 and mean difference 5.857).

Figure 4 shows the bar chart comparison of TSR and PO algorithm methods. TSR ($\approx 200\text{kW}$) produces better output power than PO ($\approx 192\text{kW}$).

Fig. 4 - Comparison of TSR and PO algorithms in terms of mean speed and output power. The mean output power of TSR is better than PO algorithm and the SD of TSR is slightly better than PO. X Axis: TSR Vs PO methods Y Axis: Mean output power of detection ± 1 SD.

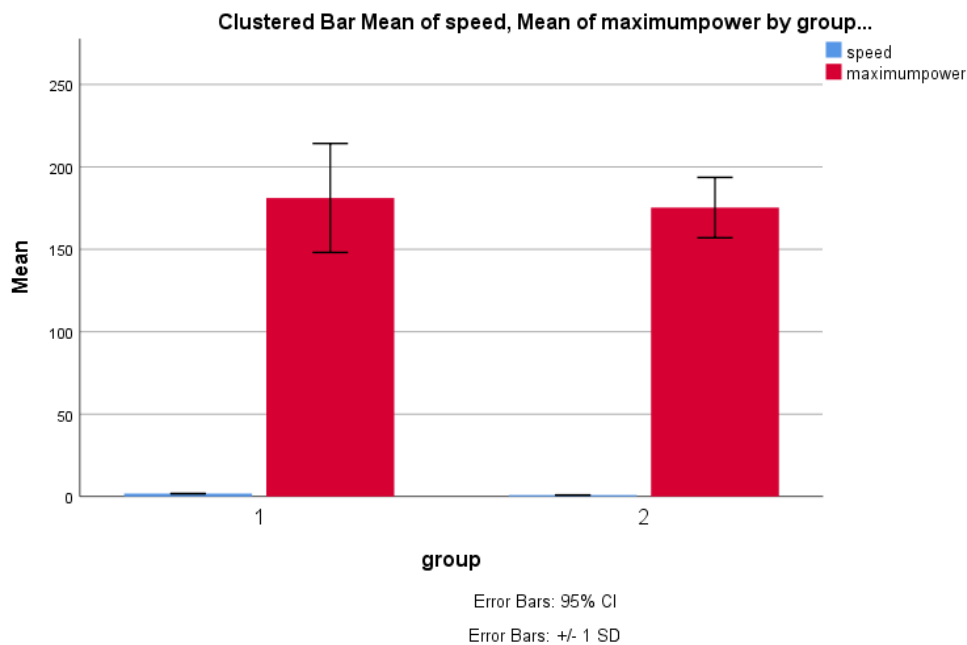

4. Discussions

In this paper TSR and PO methods are implemented to limit the wind speed for obtaining maximum output power. These two methods are used to limit the wind speed of wind turbines. Two methods were implemented in the MATLAB© simulink model and the results were compared. From the obtained results TSR (200 kW) based method produces better output power than PO (192 kW) based wind turbine control method.

The aim of wind turbine control is to provide safe, stable, efficient and economical performance in wind power production. Various methodologies are used in the literature to control the wind turbine like pitch, yaw, tip speed ratio, MPPT, PO algorithm and rotational speed control (Menezes, Araújo, and da Silva 2018). Based on the existing literature, the comparative analysis of TSR and PO methods have been carried out and it is found that TSR produces better output power

than PO (Ali et al. 2020). TSR and PO based methods were carried out and its performance was analyzed based on wind speed and output power which ensures that TSR (1. 3MW) provides better results than PO (1. 2 MW). (Guruambeth and Ramabadran 2016). The comparative analysis of various methods is carried out under varying wind speeds (above and below) and its performance is analysed based on output power. It is found that TSR (188kW) provides better results than other existing methods (Apata and Oyedokun 2020). The authors have compared the fluctuations of wind turbines using TSR and OT methods. From the results TSR provides less fluctuations optimal values (9. 5) than OT (12. 4) (Hur and Leithead 2017). During the particular time range of (380–500 s) the wind speed by the TSR method gave less variation than MPPT method (Bianchi, de Battista, and Mantz 2006). Comparing the power improvement performance of wind turbines using TSR and OT has been discussed in ((Song et al. 2017). TSR increased output power about 42. 7% which is better than 35. 5% obtained by OT method.

Tip speed ratio method produces slightly oscillation than PO in the wind turbine which reduces the stability of the system (TSR=0. 6780 p. u & PO=0. 7210 p. u). PO algorithm is not optimal for extracting maximum power from large-scale wind turbines with a large inertia. Whereas the PSF (2. 3MW) based control provides maximum power extraction than PO (1. 4MW) method for large scale wind turbines (Apata and Oyedokun 2020).

From the existing literature survey, only few articles ensure that the OT and PSF methods provide better performance than TSR and PO. Compared to the other conventional methods, the wind turbine control by TSR method almost requires no additional cost and therefore receives intense attention in recent years. Also provides maximum output power from the wind turbine by limiting the wind speed. So we can infer that TSR can be used to control the wind turbine for extracting maximum power.

Our institution is passionate about high quality evidence based research and has excelled in various fields (Vijayashree Priyadharsini 2019; Ezhilarasan, Apoorva, and Ashok Vardhan 2019; Ramesh et al. 2018; Mathew et al. 2020; Sridharan et al. 2019; Pc, Marimuthu, and Devadoss 2018; Ramadurai et al. 2019). We hope this study adds to this rich legacy.

This simulation study was only validated with a 400W wind turbine simulation model. Implementation of proposed TSR and PO with various rated wind turbines would be helpful to understand the capability and limitation of the proposed control method. For an economic reason, the TSR method tracks an optimal speed reference calculated by estimated variables from the non-standard extended Kalman filter (EKF) based wind estimation algorithm which causes stability issues in the system.

The future study of this present research is to develop a new technology for measuring wind information by an advanced sensing device, such as lidar, whereas the other is to use the estimated controller for wind speed measurement.

5. Conclusion

Based on the obtained results the TSR provides better output power (200KW) compared to the PO (192KW).

Declarations

Conflict of Interests: No conflict of interest in this manuscript.

Author Contributions

Author KS was involved in data collection, data analysis, and manuscript writing. Author TY was involved in data validation and review of manuscripts.

Acknowledgments

The authors would like to express their gratitude towards Saveetha School of Engineering, Saveetha Institute of Medical and Technical Sciences (Formerly known as Saveetha University) for providing the necessary infrastructure to carry out this work successfully.

Funding: We thank the following organizations for providing financial support that enabled us to complete the study.

1. Menaka Electricals Pvt. Ltd.,
2. Saveetha University.
3. Saveetha Institute of Medical and Technical Sciences.
4. Saveetha School of Engineering.

References

Ali, Mustafa M., Abdel-raheem Youssef, Ahmed S. Ali, and G.T. Abdel-Jaber. 2020. "Variable Step Size PO MPPT Algorithm Using Model Reference Adaptive Control for Optimal Power Extraction." *International Transactions on Electrical Energy Systems*. <https://doi.org/10.1002/2050-7038.12151>.

- Ananth, D.V.N., and Gundavarapu Venkata Nagesh Kumar. 2016. "Tip Speed Ratio Based MPPT Algorithm and Improved Field Oriented Control for Extracting Optimal Real Power and Independent Reactive Power Control for Grid Connected Doubly Fed Induction Generator." *International Journal of Electrical and Computer Engineering (IJECE)*. <https://doi.org/10.11591/ijece.v6i3.pp1319-1331>.
- Apata, O., and D.T.O. Oyedokun. 2020. "An Overview of Control Techniques for Wind Turbine Systems." *Scientific African*. <https://doi.org/10.1016/j.sciaf.2020.e00566>.
- Assareh, Ehsanolah, and Mojtaba Biglari. 2015. "A Novel Approach to Capture the Maximum Power from Variable Speed Wind Turbines Using PI Controller, RBF Neural Network and GSA Evolutionary Algorithm." *Renewable and Sustainable Energy Reviews*. <https://doi.org/10.1016/j.rser.2015.07.034>.
- Bianchi, Fernando D., Hernán de Battista, and Ricardo J. Mantz. 2006. *Wind Turbine Control Systems: Principles, Modelling and Gain Scheduling Design*. Springer Science & Business Media.
- Bilal, Aamer, and Xiaodong Liu. 2018. "Online Estimation of Wind Turbine Tip Speed Ratio by Adaptive Neuro-Fuzzy Algorithm." *International Journal of Advanced Computer Science and Applications*. <https://doi.org/10.14569/ijacs.2018.090306>.
- Ezhilarasan, Devaraj, Velluru S. Apoorva, and Nandhigam Ashok Vardhan. 2019. "Syzygium Cumini Extract Induced Reactive Oxygen Species-Mediated Apoptosis in Human Oral Squamous Carcinoma Cells." *Journal of Oral Pathology & Medicine: Official Publication of the International Association of Oral Pathologists and the American Academy of Oral Pathology* 48 (2): 115–21.
- Gheena, S., and D. Ezhilarasan. 2019. "Syringic Acid Triggers Reactive Oxygen Species-Mediated Cytotoxicity in HepG2 Cells." *Human & Experimental Toxicology* 38 (6): 694–702.
- Ghiasi, Pedram, Gholamhassan Najafi, Barat Ghobadian, and Ali Jafari. 2021. "Analytical and Numerical Solution for H-Type Darrieus Wind Turbine Performance at the Tip Speed Ratio of Below One." *International Journal of Renewable Energy Development*. <https://doi.org/10.14710/ijred.2021.33169>.
- Hur, S., and W.E. Leithead. 2017. "Model Predictive and Linear Quadratic Gaussian Control of a Wind Turbine." *Optimal Control Applications and Methods*. <https://doi.org/10.1002/oca.2244>.
- Jose, Jerry, Ajitha, and Haripriya Subbaiyan. 2020. "Different Treatment Modalities Followed by Dental Practitioners for Ellis Class 2 Fracture – A Questionnaire-Based Survey." *The Open Dentistry Journal* 14 (1): 59–65.
- Ke, Yang, Mohammed Saleh Al Aboody, Wael Alturaiki, Suliman A. Alsagaby, Faiz Abdulaziz Alfaiz, Vishnu Priya Veeraraghavan, and Suresh Mickymaray. 2019. "Photosynthesized Gold Nanoparticles from *Catharanthus Roseus* Induces Caspase-Mediated Apoptosis in Cervical Cancer Cells (HeLa)." *Artificial Cells, Nanomedicine, and Biotechnology* 47 (1): 1938–46.
- Krishnaswamy, Haribabu, Sivaprakash Muthukrishnan, Sathish Thanikodi, Godwin Arockiaraj Antony, and Vijayan Venkatraman. 2020. "Investigation of Air Conditioning Temperature Variation by Modifying the Structure of Passenger Car Using Computational Fluid Dynamics." *Thermal Science* 24 (1 Part B): 495–98.
- Malli Sureshbabu, Nivedhitha, Kathiravan Selvarasu, Jayanth Kumar V, Mahalakshmi Nandakumar, and Deepak Selvam. 2019. "Concentrated Growth Factors as an Ingenious Biomaterial in Regeneration of Bony Defects after Periapical Surgery: A Report of Two Cases." *Case Reports in Dentistry* 2019 (January): 7046203.

- Ma, Ning, Hang Lei, Zhaolong Han, Dai Zhou, Yan Bao, Kai Zhang, Lei Zhou, and Caiyong Chen. 2018. "Airfoil Optimization to Improve Power Performance of a High-Solidity Vertical Axis Wind Turbine at a Moderate Tip Speed Ratio." *Energy*. <https://doi.org/10.1016/j.energy.2018.02.115>.
- Mathew, M.G., S.R. Samuel, A.J. Soni, and K.B. Roopa. 2020. "Evaluation of Adhesion of Streptococcus Mutans, Plaque Accumulation on Zirconia and Stainless Steel Crowns, and Surrounding Gingival Inflammation in Primary" *Clinical Oral Investigations*. <https://link.springer.com/article/10.1007/s00784-020-03204-9>.
- Mehta, Meenu, Deeksha, Devesh Tewari, Gaurav Gupta, Rajendra Awasthi, Harjeet Singh, Parijat Pandey, et al. 2019. "Oligonucleotide Therapy: An Emerging Focus Area for Drug Delivery in Chronic Inflammatory Respiratory Diseases." *Chemico-Biological Interactions* 308 (August): 206–15.
- Menezes, Eduardo José Novaes, Alex Maurício Araújo, and Nadège Sophie Bouchonneau da Silva. 2018. "A Review on Wind Turbine Control and Its Associated Methods." *Journal of Cleaner Production*. <https://doi.org/10.1016/j.jclepro.2017.10.297>.
- Muthukrishnan, Sivaprakash, Haribabu Krishnaswamy, Sathish Thanikodi, Dinesh Sundaresan, and Vijayan Venkatraman. 2020. "Support Vector Machine for Modelling and Simulation of Heat Exchangers." *Thermal Science* 24 (1 Part B): 499–503.
- Ochieng, P. O., A. W. Manyonge, and Andrew O. Oduor. 2014. "Mathematical Analysis of Tip Speed Ratio of a Wind Turbine and Its Effects on Power Coefficient." *International Journal of Mathematics and Soft Computing*. <https://doi.org/10.26708/ijmsc.2014.1.4.07>.
- Pc, J., T. Marimuthu, and P. Devadoss. 2018. "Prevalence and Measurement of Anterior Loop of the Mandibular Canal Using CBCT: A Cross Sectional Study." *Clinical Implant Dentistry and Related Research*. <https://europepmc.org/article/med/29624863>
- P., Dinakara Prasas Reddy, Veera Reddy V.C., and Gowri Manohar T. 2018. "Ant Lion Optimization Algorithm for Optimal Sizing of Renewable Energy Resources for Loss Reduction in Distribution Systems." *Journal of Electrical Systems and Information Technology*. <https://doi.org/10.1016/j.jesit.2017.06.001>.
- Posa, Antonio. 2020. "Influence of Tip Speed Ratio on Wake Features of a Vertical Axis Wind Turbine." *Journal of Wind Engineering and Industrial Aerodynamics*. <https://doi.org/10.1016/j.jweia.2019.104076>.
- Ramadurai, Neeraja, Deepa Gurunathan, A. Victor Samuel, Emg Subramanian, and Steven J. L. Rodrigues. 2019. "Effectiveness of 2% Articaine as an Anesthetic Agent in Children: Randomized Controlled Trial." *Clinical Oral Investigations* 23 (9): 3543–50.
- Ramesh, Asha, Sheeja Varghese, Nadathur D. Jayakumar, and Sankari Malaiappan. 2018. "Comparative Estimation of Sulfiredoxin Levels between Chronic Periodontitis and Healthy Patients - A Case-Control Study." *Journal of Periodontology* 89 (10): 1241–48.
- Samokhvalov, Dmitry V., Ahmed I. Jaber, Dmitriy M. Filippov, Anatoliy N. Kazak, and Mohammed S. Hasan. 2020. "Research of Maximum Power Point Tracking Control for Wind Generator." *2020 IEEE Conference of Russian Young Researchers in Electrical and Electronic Engineering (EICoN Rus)*. <https://doi.org/10.1109/eiconrus49466.2020.9039180>.
- Samuel, Melvin S., Jayanta Bhattacharya, Sankalp Raj, Needhidasan Santhanam, Hemant Singh, and N. D. Pradeep Singh. 2019. "Efficient Removal of Chromium(VI) from Aqueous Solution Using

Chitosan Grafted Graphene Oxide (CS-GO) Nanocomposite.” *International Journal of Biological Macromolecules* 121 (January): 285–92.

Samuel, Srinivasan Raj, Shashidhar Acharya, and Jeevika Chandrasekar Rao. 2020. “School Interventions-Based Prevention of Early-Childhood Caries among 3-5-Year-Old Children from Very Low Socioeconomic Status: Two-Year Randomized Trial.” *Journal of Public Health Dentistry* 80 (1): 51–60.

Sathish, T., and S. Karthick. 2020. “Wear Behaviour Analysis on Aluminium Alloy 7050 with Reinforced SiC through Taguchi Approach.” *Journal of Japan Research Institute for Advanced Copper-Base Materials and Technologies* 9 (3): 3481–87.

Sharma, Parvarish, Meenu Mehta, Daljeet Singh Dhanjal, Simran Kaur, Gaurav Gupta, Harjeet Singh, Lakshmi Thangavelu, et al. 2019. “Emerging Trends in the Novel Drug Delivery Approaches for the Treatment of Lung Cancer.” *Chemico-Biological Interactions* 309 (August): 108720.

Song, Dongran, Jian Yang, Mei Su, Anfeng Liu, Yao Liu, and Young Joo. 2017. “A Comparison Study between Two MPPT Control Methods for a Large Variable-Speed Wind Turbine under Different Wind Speed Characteristics.” *Energies*. <https://doi.org/10.3390/en10050613>.

Sridharan, Gokul, Pratibha Ramani, Sangeeta Patankar, and Rajagopalan Vijayaraghavan. 2019. “Evaluation of Salivary Metabolomics in Oral Leukoplakia and Oral Squamous Cell Carcinoma.” *Journal of Oral Pathology & Medicine: Official Publication of the International Association of Oral Pathologists and the American Academy of Oral Pathology* 48 (4): 299–306.

Varghese, Sheeja Saji, Asha Ramesh, and Deepak Nallaswamy Veeraiyan. 2019. “Blended Module-Based Teaching in Biostatistics and Research Methodology: A Retrospective Study with Postgraduate Dental Students.” *Journal of Dental Education* 83 (4): 445–50.

Venu, Harish, V. Dhana Raju, and Lingesan Subramani. 2019. “Combined Effect of Influence of Nano Additives, Combustion Chamber Geometry and Injection Timing in a DI Diesel Engine Fuelled with Ternary (diesel-Biodiesel-Ethanol) Blends.” *Energy* 174 (May): 386–406.

Venu, Harish, Lingesan Subramani, and V. Dhana Raju. 2019. “Emission Reduction in a DI Diesel Engine Using Exhaust Gas Recirculation (EGR) of Palm Biodiesel Blended with TiO₂ Nano Additives.” *Renewable Energy* 140 (September): 245–63.

Vignesh, R., Ditto Sharmin, C. Vishnu Rekha, Sankar Annamalai, and Parisa Norouzi Baghkomeh. 2019. “Management of Complicated Crown-Root Fracture by Extra-Oral Fragment Reattachment and Intentional Reimplantation with 2 Years Review.” *Contemporary Clinical Dentistry* 10 (2): 397–401.

Vijayakumar Jain, S., M. R. Muthusekhar, M. F. Baig, P. Senthilnathan, S. Loganathan, P. U. Abdul Wahab, M. Madhulakshmi, and Yogaen Vohra. 2019. “Evaluation of Three-Dimensional Changes in Pharyngeal Airway Following Isolated Lefort One Osteotomy for the Correction of Vertical Maxillary Excess: A Prospective Study.” *Journal of Maxillofacial and Oral Surgery* 18 (1): 139–46.

Vijayashree Priyadharsini, Jayaseelan. 2019. “In Silico Validation of the Non-Antibiotic Drugs Acetaminophen and Ibuprofen as Antibacterial Agents against Red Complex Pathogens.” *Journal of Periodontology* 90 (12): 1441–48.