

Design of Novel Dual Band Rectangular Patch Antenna (DB-RPA) to Enhance the Gain and Comparing with Circular Patch Antenna

A. Benu Gopala Krishna Murthy¹; G. Uganya^{2*}

¹Research Scholar, Department of Electronics and Communication Engineering, Saveetha School of Engineering, Saveetha Institute of Medical and Technical Sciences, Saveetha University, Chennai, Tamil Nadu, India.

¹benuannavarapu.3@gmail.com

^{2*}Project Guide, Department of Electronics and Communication Engineering, Saveetha School of Engineering, Saveetha Institute of Medical and Technical Sciences, Saveetha University, Chennai, Tamil Nadu, India.

^{2*}uganyag.sse@saveetha.com

Abstract

Aim: Microstrip patch antennas are rapidly used in the areas of wireless systems due to its low cost and lightweight. But still it has research issues like narrow bandwidth, poor efficiency, and low gain. The objective of this study is to enhance the gain of Novel DB-RPA antenna. This work presents the comparative analysis of gain enhancement between rectangular and circular patch antennas. **Materials & Methods:** Dual band rectangular patch antenna (DB-RPA) and circular patch antenna (CPA) are designed to enhance the gain of the antenna by using HFSS software and by collecting the dataset of 40 samples with pretest power of 80%. The gain of CPA is 1.89 dB and DB-RPA is 4.66 dB. The directivity of CPA is 3.52 dB and DB-RPA is 4.89 dB. **Results:** On performing an independent sample t-test on the two groups considered, it appears that the mean gain of Novel DB-RPA is 3.0755 and CPA is 0.8820 with significance value of 0.001 ($p < 0.05$). **Conclusion:** From this study, it is found that DB-RPA design appears to have 71% higher gain and 58% higher directivity with comparison of CPA design.

Keywords: Antenna Design, Dual Band, Rectangular Patch, Circular Patch, Duroid, Inset Feed Technique, Novel DB-RP Antenna.

1. Introduction

With the rapid growth of wireless systems and demands for the low power integrated electronic circuits, microstrip antennas have taken for the gain enhancement (Aboualalaa et al. 2017). Generally, a microstrip patch antenna has a low weight and low profile. In a microstrip antenna two metallic layers

and a dielectric layer form the essential part of the basic antenna (R. G. Mishra, Mishra, and Kuchhal 2018). A transmitter is essential in modern wireless communication devices, the antenna is expected to effectively send and receive the signals (Han, Song, and Sheng 2017). There are many advantages for microstrip antennas like ease of fabrication, low cost and easy integration with microwave antennas (Yadav, Singh, and Melkeri 2017). Microstrip antennas are used in various fields like military, navy, wearable and mobile applications.

Several methods for enhancing the gain of a microstrip antenna have been implemented over the years for making the antenna suitable for strong wireless communication for longer distances (Kumar and Kumar 2014). Mohamed Aboualalaa et al. proposed an antenna to explain its electrical behavior (Aboualalaa et al. 2017). It consists of a direct feed through feed line that is specially designed to radiate at 2.45 GHz. Anju Verma et al. proposed slotted microstrip patch antenna with a defected ground structure (DGS) (Verma et al. 2016). This antenna shows dual band characteristics which is suitable for WLAN and Wi-MAX applications. Rahmatian et al. proposed a single layer dual-band dual-mode metamaterial microstrip patch antenna for on and off-body communications (Rahmatian, Movahhedi, and Yazdi 2018). The antenna radiates at 2.45 GHz ISM band and 5.3 GHz WLAN band. Nguyen et al. proposed a CPW-fed flexible antenna which can be able to work at two different operating frequencies (Nguyen, Nguyen, and Vuong 2019). Zheng et al. proposed an antenna for wideband gain enhancement and radar cross-section (RCS) reduction of Fabry-Perot (FP) resonator antenna are both achieved by using chessboard-arranged metamaterial superstrate (CAMS) (Zheng et al. 2018). Han et al. proposed designing a novel antenna to enhance the gain and reduce the radar cross section (RCS) of a patch antenna by using metamaterial surface (Han, Song, and Sheng 2017). Hui Li et al. proposed a flexible MIMO antenna system with pattern diversities and polarization has been proposed for wearable applications. The antenna has only one conducting layer and is easy to integrate in clothing (Li, Sun, and Wang 2018). Fan Qin et al. proposed a novel shaped-aperture dual band dual-polarized high gain antenna for potential applications in synthetic aperture radars (SAR) (Qin et al. 2016). Faisal et al. proposed a miniaturized novel shape dual-band implantable antenna operating in the industrial, scientific, and medical bands is developed for battery powered implants (Faisal and Yoo 2019). It suggests that the antenna designed in flower shape exhibits fairly omni-directional radiation patterns. Therefore, it can be used for skin implantations and gastro applications (Rachmansyah et al. 2011).

Previously our team has a rich experience in working on various research projects across multiple disciplines (Sathish and Karthick 2020; Varghese, Ramesh, and Veeraiyan 2019; S. R. Samuel, Acharya, and Rao 2020; Venu, Raju, and Subramani 2019; M. S. Samuel et al. 2019; Venu, Subramani, and Raju 2019; Mehta et al. 2019; Sharma et al. 2019; Malli Sureshbabu et al. 2019; Krishnaswamy et

al. 2020; Muthukrishnan et al. 2020; Gheena and Ezhilarasan 2019; Vignesh et al. 2019; Ke et al. 2019; Vijayakumar Jain et al. 2019; Jose, Ajitha, and Subbaiyan 2020). Now the growing trend in this area motivated us to pursue this project.

Microstrip antennas have several advantages including low cost, lightweight and capable of dual frequency band operations. But still it has research issues like narrow bandwidth, poor efficiency, low gain and power handling capacity. Motivated by these research issues, Novel DB- RPA antenna is designed and it can be rapidly used in various fields of communication for their compact size, high performance and versatility (Deb, Moyra, and Bhowmik 2015). The proposed antenna is designed using Duroid substrate. It is used as a dielectric substrate since it has good thermal, electrical and high durability. Inset Feed helps to match the impedance of the antenna which in turn reduces the power loss.

2. Materials & Methods

This study was conducted at Antenna Lab in Saveetha School of Engineering. It was based on gain improvement of microstrip patch antenna using duroid substrate, rectangular patch in comparison with circular patch antenna. Sample size was calculated by using previous study results (Nguyen, Nguyen, and Vuong 2019) using clinicalcalc.com by keeping alpha error threshold by 0.05, 95% confidence interval, power 80%. In this study we compare the parameter such as gain with one sample group from previous literature.

In this work, we have taken two groups into consideration. The first group was designed by using circular patches and the second group was designed by using the rectangular patch for enhancing the gain. The dataset of 20 samples were collected from the CPA and another 20 samples from RPA (Kane, Phar, and BCPS n.d.). The samples that were collected from the simulated results using Ansoft HFSS software. Independent variables for designing an antenna are width of substrate, height of substrate, patch length and then patch width (R. Mishra, Kuchhal, and Kumar 2015). Dependent variables in designing an antenna are gain and directivity. These parameters are responsible for designing the antenna.

2.1. Design Configuration

The proposed Novel DB-RPA was designed by using a Duroid substrate with dielectric constant of 2.33. The inset-feed was given by removing the edge of the non-radiating patch to allow for the planar feeding mechanism. The design was implemented using Ansoft HFSS simulation software.

The patch dimensions were calculated by using the design equations of the microstrip antenna.

Patch width is denoted by W_p

$$W_p = c / (2 * F_0 * (\epsilon_r + 1/2)^{0.5}) \quad (1)$$

Length of the patch is denoted by L_p

$$L_p = (\lambda/2) - 2dL \quad (2)$$

Length extension is denoted by dL

$$dL = 0.412H(\epsilon_{eff} + 0.3)/(\epsilon_{eff} - 0.258) * ((W_p/H + 0.264)/(W_p/H + 0.8)) \quad (3)$$

Effective dielectric constant is denoted by ϵ_{eff}

$$\epsilon_{eff} = (\epsilon_r + 1)/2 \quad (4)$$

From the above equations, the ground dimensions can be designed as

Length of ground is denoted by L_g

$$L_g = L_p + 6H \quad (5)$$

Width of ground is denoted as W_g

$$W_g = W_p + 6H \quad (6)$$

2.2. CPA Antenna Design

Circular Patch Antenna was designed by using the Flame Retardant 4 (FR4) substrate, sandwiched between circular patch and ground plane is shown in Fig.1. The antenna has a patch length of 60 mm and patch width of 40 mm. The height of substrate material is 2 mm. Because of these characteristics, there is an impact on the gain of the antenna.

Fig. 1 - The circular patch antenna has been designed with a low gain, high dielectric constant ($\epsilon = 4.4$), patch length of 60mm and width of 40mm

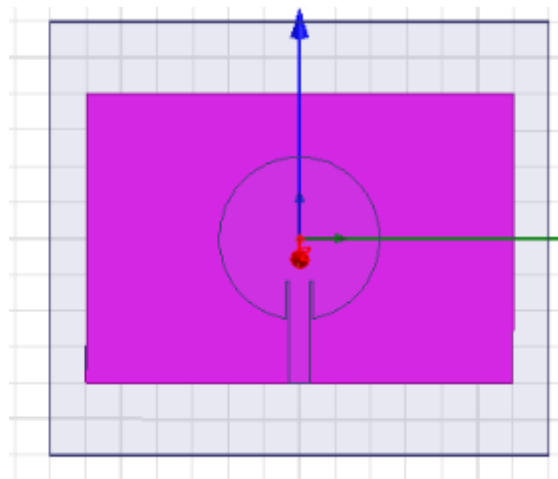
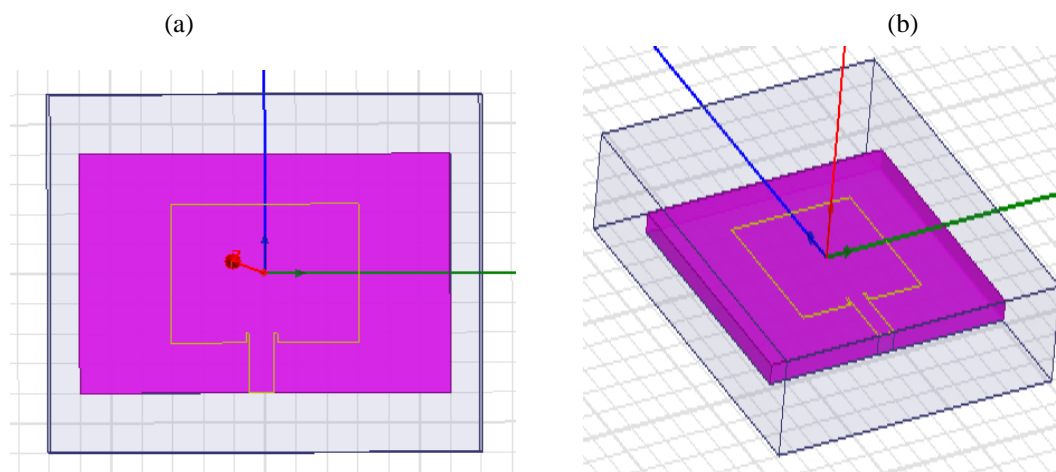

Fig. 2 - Design of DB-RPA Antenna with Duroid substrate of dielectric constant with $\epsilon = 2.33$ a) Top View b) Cross-sectional View. The antenna was designed with a patch length of 30 mm, width of 20 mm and substrate height of 2 mm.



2.3. Novel DB-RPA Antenna Design

Novel DB-RPA design was made up of a low profile and flexible rectangular patch is shown in Fig.2. It was designed and fabricated by using duroid substrate ($\epsilon = 2.33$) with a thickness of 2mm is shown in Table 1. On the other side, the feed mechanism plays a vital role in the design of Novel DB-RPA (“Design and Development of Inset Feed Microstrip Patch Antennas Using Various Substrates” 2019). An inset-feed microstrip patch antenna was designed to increase the gain and bandwidth.

Table 1 - Design Parameters for DB-RPA. It was designed by duroid substrate material with patch length of 30 mm and width of 20 mm using Ansoft HFSS software.

Patch type	Rectangular
Dielectric constant	2.33
Height of substrate	2 mm
Feeding type	Inset feed
Patch length	30 mm
Patch width	20 mm
Substrate material	Duroid

2.4. Statistical Analysis

The testing procedure initiates with designing of antenna, mathematical calculations, frequency specification, assigning variables, construction of antenna using HFSS software and analyzing the results by SPSS software. SPSS version 21 (Statistical Package for the Social Sciences) was used for statistical analysis for various varieties of research. The data collected from the research was stored in

a data view. After entering the data in the data view sheet, data can be analyzed by using the Analyze option. By clicking on the chart builder, a graph will be formed showing the performance of the design. Dependent variables of rectangular patch design were gain and directivity. These parameters are responsible for determining the values of an antenna. If the dielectric constant value of the substrate increases then the gain of that particular antenna will decrease (Roy, Mom, and Kureve 2013).

3. Results

From Fig.3, it was observed that the peak gain obtained from CPA design is 1.89 dB and the peak directivity is 3.52 dB. The substrate used in it's design was having higher dielectric value, due to this it produces low gain. Due to the presence of low gain, the performance of circular patch antennas decreases.

Fig. 3 - Simulation results for CPA a) Gain (dB) Vs Frequency (GHz) is plotted and peak gain is 1.89 dB in the frequency range from 1 to 7 GHz. b) Directivity (dB) Vs Frequency (GHz) is plotted and peak directivity is 3.52 dB.

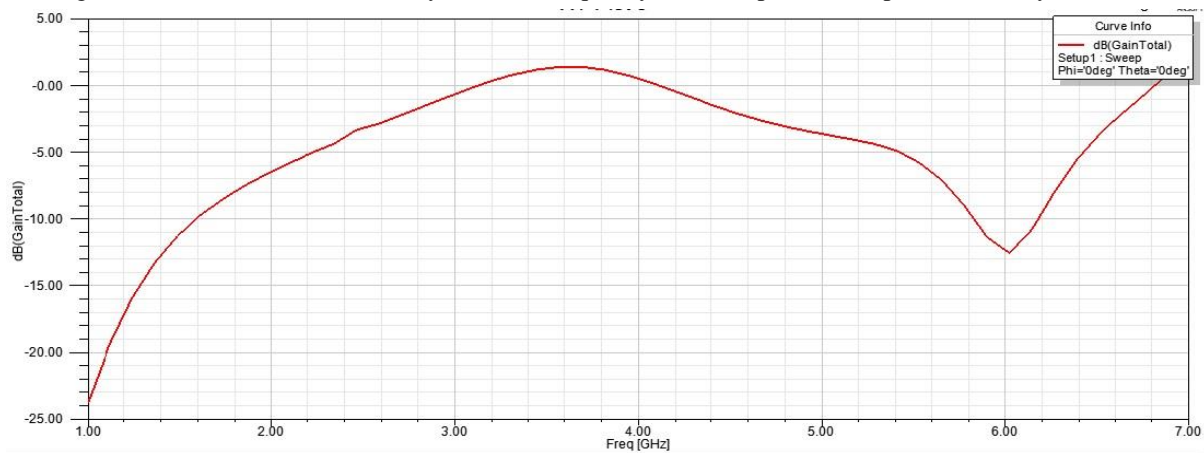

(a)

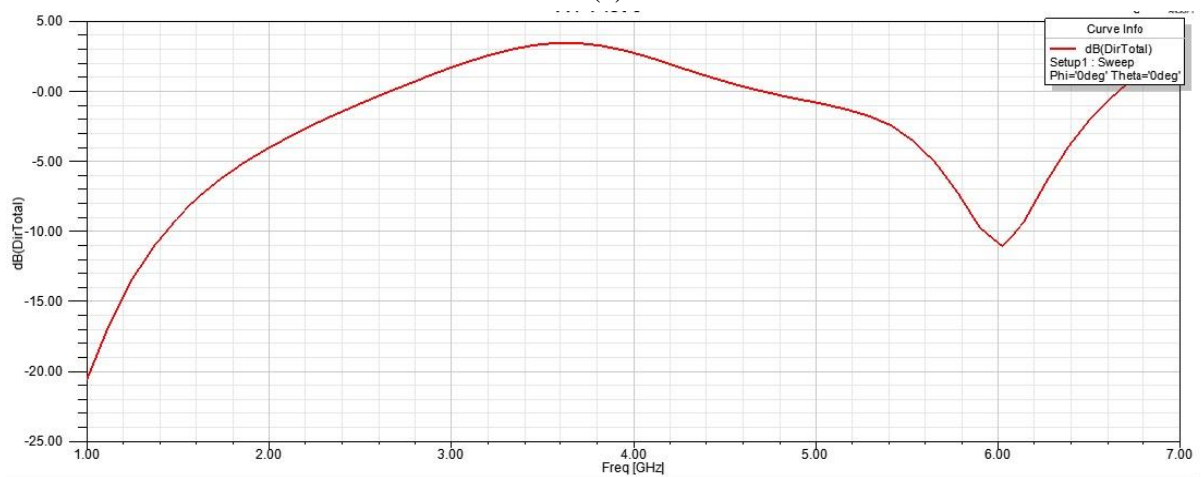

(b)

From Fig.4, it was observed that the peak gain obtained from Novel DB-RPA design is 4.66 dB and the peak directivity is 4.89 dB. Because of using a lower dielectric substrate in the design, it achieves higher gain when compared to CPA design. For the better performance of the antenna, the thick substrate with low permittivity is preferred. The results of the Novel DB-RPA are analyzed by using Ansoft HFSS simulation tool.

Fig. 4 - Simulation results for DB-RPA a) Gain (dB) Vs Frequency (GHz) is plotted and the maximum gain obtained is 4.66 dB in the frequency range from 1 to 8 GHz. b) Directivity (dB) Vs Frequency (GHz) is plotted and the maximum directivity obtained is 4.89 dB in the frequency range from 1 to 8 GHz.

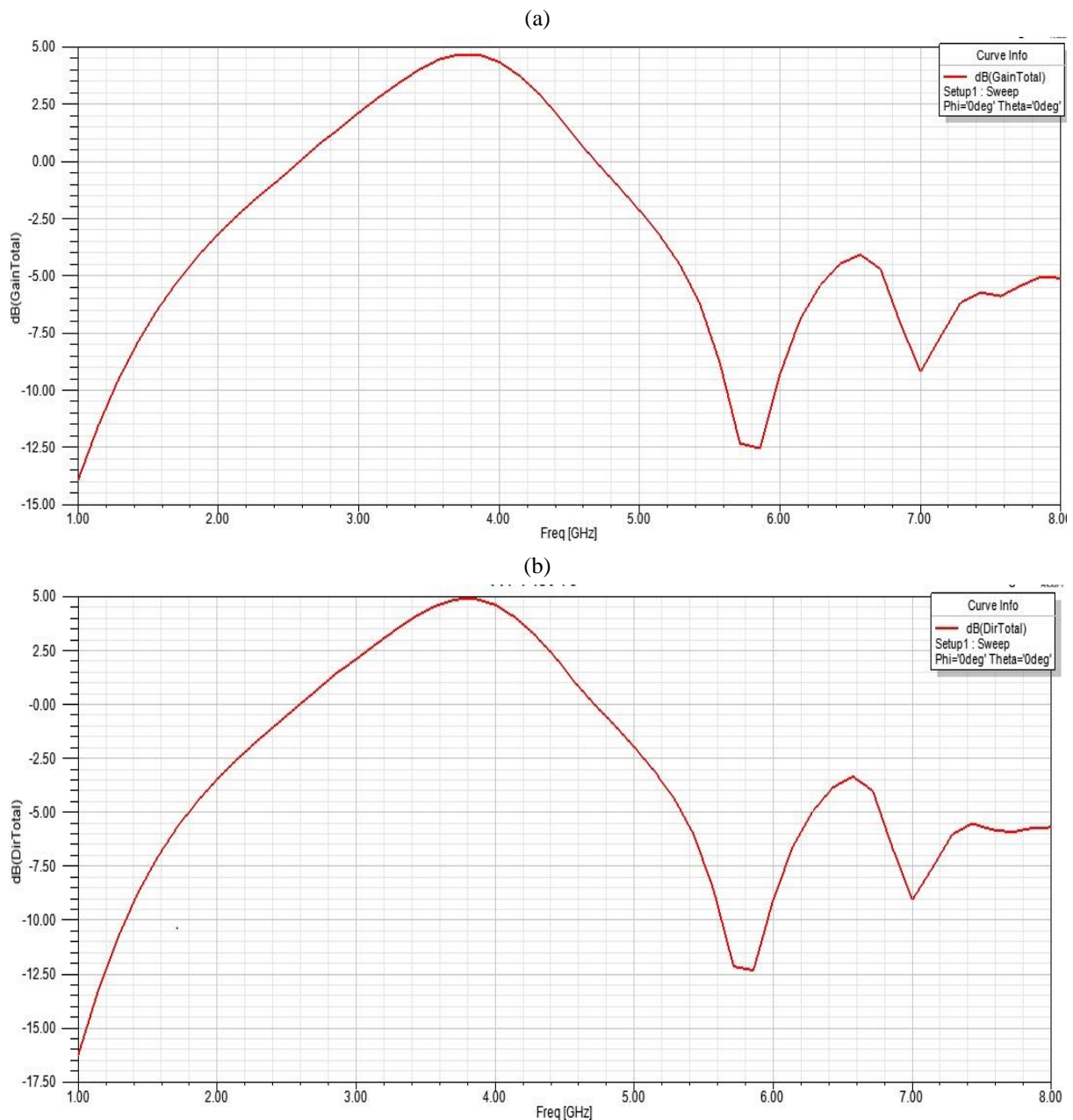

In statistical inference, two groups are taken for statistical analysis. One of the groups is CPA design and other is Novel DB-RPA design. Each group has been analyzed by taking 20 samples each. Circular patch antenna obtained 0.52 standard deviation with mean 0.88 while rectangular patch antenna obtained 2.51 standard deviation with mean 3.07 (Table 2).

Table 2 - Group statistics shows the clear observation of statistical data for each group accordingly. Each group contains an equal number of samples. Rectangular patch has a mean gain of 3.0755 which is higher and a circular patch antenna has the lowest mean of 0.8820. Statistical analysis has been done by using SPSS software.

Parameters	Group	N	Mean	Std. Deviation
Gain	Circular patch	20	0.8820	0.52804
	Rectangular patch	20	3.0755	2.51725

*N = Number of samples

For the Independent Samples T-test equality means for every group and F-score are considered. The significance value obtained from the T-test is 0.001. By changing the input values (independent variables) the corresponding output values (dependent variables) also changes (Table 3).

Table 3 - For the Independent Samples test, F-score and significance are calculated for Levene's Test, Equality of variances are taken. Whereas for T-test equality means are calculated. The significance value for gain is 0.001. There is a significant difference between the two groups since $p < 0.05$.

		Levene's Test for Equality of Variances		T-test for Equality of Means						
		F	Sig.	t	df	Sig. (2-tailed)	Mean Difference	Std. Error Difference	95% Confidence interval of the Difference	
									Lower	Upper
Gain	Equal Variances assumed	11.789	0.001	-3.814	38	0.001	-2.19350	0.57512	-3.35778	-1.02922
	Equal variances not assumed			-3.814	20.669	0.001	-2.19350	0.57512	-3.39071	0.99629

From Fig.5, it was observed that in comparison with a circular patch, the proposed Novel DB-RPA antenna appears to have 71% more gain. The graph of mean gain of circular patch and rectangular patch is obtained from the samples. After analyzing the statistical results, the Novel DB-RPA antenna appears to be better than CPA.

Fig. 5 - Comparison of CPA and DB-RPA in terms of mean gain. The mean gain of DB-RPA appears to be better than CPA. X Axis: Circular Patch Antenna vs Dual band Rectangular Patch Antenna, Y Axis: Mean gain of detection \pm 1 SD

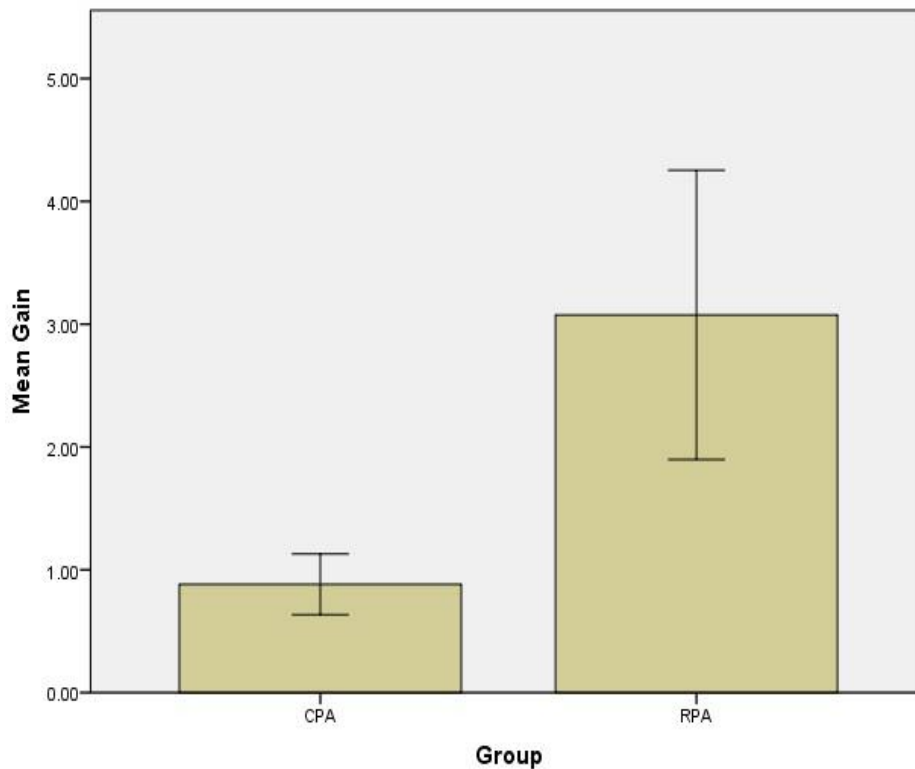

4. Discussion

In this study, we observed that Novel DB-RPA appears to be better than CPA with 71% more gain ($p < 0.05$). Gain and directivity of circular patch and rectangular patch antenna are analyzed by varying the substrate material. The gain Vs frequency has been simulated for a different frequency range from (1-8) GHz. The gain of the Novel DB-RPA antenna is 4.66 dB and directivity is 4.89 dB. The gain of CPA is 1.89 dB and directivity is 3.52 dB. After analyzing the results obtained from HFSS, samples are collected from the resulting graph. By performing the group statistics and independent sample T-test, it is observed that the gain and directivity of the rectangular patch appears to be better when compared to the circular patch antenna.

The factors that affect the designing of an antenna are width of substrate, height of substrate, patch length and width. The efficiency of an antenna depends on the thickness of the substrate. If the substrate thickness increases, then the gain percentage also increases. The antenna radiates based on substrate material. The patch antenna by using polarization dependent EBG surface is having a gain of 2.5 dB (Han, Song, and Sheng 2017). It is having less gain because the antenna is designed by the layout pattern of the slotted EBG elements. The proposed Novel DB-RPA is having more gain due to

its smaller size compared to the EBG antenna. The U-shaped microstrip antenna has a gain of range 1.6 to 5.3 dB (Koohestani and Golpour 2010). It has low gain due to square patch which is fed by CPW. The microstrip patch antenna with parasitic mushroom type structure is having a gain of 10 dB (Cao et al. 2019). This is because the current distributions on the patches are uniformly distributed, so that higher gain is achieved over the entire operating frequency.

Our institution is passionate about high quality evidence based research and has excelled in various fields (Vijayashree Priyadharsini 2019; Ezhilarasan, Apoorva, and Ashok Vardhan 2019; Ramesh et al. 2018; Mathew et al. 2020; Sridharan et al. 2019; Pc, Marimuthu, and Devadoss 2018; Ramadurai et al. 2019). We hope this study adds to this rich legacy.

Designing an antenna is difficult for higher bands like X band and K band. More radiation occurs from the feeding and junctions of an antenna. This work can be elaborated for multi band frequencies in various fields such as military applications, satellite communications, mobile applications and global positioning systems for navigation. By reducing the size of an antenna, performance can be increased. To be implemented in hardware as there is much demand in wireless communication.

5. Conclusion

A Rectangular Patch Antenna of low profile has been designed in this work to enhance the gain. It radiates at a frequency range of 5.8 GHz with gain of 4.66 dB. From the above results, it can be concluded that the gain of the Novel DB-RPA with the Duroid substrate appears to be improved by 2.77 dB compared to the CPA. This work can be elongated for multiband frequency ranges in areas like military and global positioning systems for navigation. The proposed antenna has 71% more gain and 58% more directivity than CPA.

Declarations

Conflict of interests: No conflict of interest in this manuscript.

Author Contributions

Author ABGKM was involved in data collection, data analysis and manuscript writing. Author GU was involved in the conceptualization, data validation and critical review of the manuscript.

Acknowledgement

The authors would like to express their gratitude towards Saveetha School of Engineering, Saveetha Institute of Medical and Technical Sciences (Formerly known as Saveetha University) for providing the necessary infrastructure to carry out this work successfully.

Funding: We thank the following organizations for providing financial support that enabled us to complete the study.

Global Multimedia Solutions

Saveetha University

Saveetha Institute of Medical and Technical Sciences

Saveetha School of Engineering

References

- Aboualalaa, Mohamed, Adel B. Abdel-Rahman, Ahmed Allam, Hala Elsadek, and Ramesh K. Pokharel. 2017. "Design of a Dual-Band Microstrip Antenna with Enhanced Gain for Energy Harvesting Applications." *IEEE Antennas and Wireless Propagation Letters*. <https://doi.org/10.1109/lawp.2017.2654353>.
- Cao, Yufan, Yang Cai, Wenquan Cao, Baokun Xi, Zuping Qian, Tao Wu, and Lei Zhu. 2019. "Broadband and High-Gain Microstrip Patch Antenna Loaded with Parasitic Mushroom-Type Structure." *IEEE Antennas and Wireless Propagation Letters*. <https://doi.org/10.1109/lawp.2019.2917909>.
- Deb, Partha Kumar, Tamasi Moyra, and Priyansha Bhowmik. 2015. "Dual Band Multilayer E-Shape Microstrip Patch Antenna for C-Band and X-Band." *2015 2nd International Conference on Signal Processing and Integrated Networks (SPIN)*. <https://doi.org/10.1109/spin.2015.7095320>.
- "Design And Development of Inset Feed Microstrip Patch Antennas Using Various Substrates." 2019. *International Journal of Innovative Technology and Exploring Engineering*. <https://doi.org/10.35940/ijitee.i7615.078919>.
- Ezhilarasan, Devaraj, Velluru S. Apoorva, and Nandhigam Ashok Vardhan. 2019. "Syzygium Cumini Extract Induced Reactive Oxygen Species-Mediated Apoptosis in Human Oral Squamous Carcinoma Cells." *Journal of Oral Pathology & Medicine: Official Publication of the International Association of Oral Pathologists and the American Academy of Oral Pathology* 48 (2): 115–21.
- Faisal, Farooq, and Hyongsuk Yoo. 2019. "A Miniaturized Novel-Shape Dual-Band Antenna for Implantable Applications." *IEEE Transactions on Antennas and Propagation*. <https://doi.org/10.1109/tap.2018.2880046>.
- Gheena, S., and D. Ezhilarasan. 2019. "Syringic Acid Triggers Reactive Oxygen Species-Mediated Cytotoxicity in HepG2 Cells." *Human & Experimental Toxicology* 38 (6): 694–702.
- Han, Zi-Jian, Wei Song, and Xin-Qing Sheng. 2017. "Gain Enhancement and RCS Reduction for Patch Antenna by Using Polarization-Dependent EBG Surface." *IEEE Antennas and Wireless Propagation Letters*. <https://doi.org/10.1109/lawp.2017.2658195>.

Jose, Jerry, Ajitha, and Haripriya Subbaiyan. 2020. "Different Treatment Modalities Followed by Dental Practitioners for Ellis Class 2 Fracture – A Questionnaire-Based Survey." *The Open Dentistry Journal* 14 (1): 59–65.

Kane, Sean P., Phar, and BCPS. n.d. "Sample Size Calculator." Accessed March 23, 2021. <https://clinicalcalc.com/stats/samplesize.aspx>.

Ke, Yang, Mohammed Saleh Al Aboody, Wael Alturaiki, Suliman A. Alsagaby, Faiz Abdulaziz Alfaiz, Vishnu Priya Veeraraghavan, and Suresh Mickymaray. 2019. "Photosynthesized Gold Nanoparticles from *Catharanthus Roseus* Induces Caspase-Mediated Apoptosis in Cervical Cancer Cells (HeLa)." *Artificial Cells, Nanomedicine, and Biotechnology* 47 (1): 1938–46.

Koohestani, M., and M. Golpour. 2010. "U-Shaped Microstrip Patch Antenna with Novel Parasitic Tuning Stubs for Ultra Wideband Applications." *IET Microwaves, Antennas & Propagation*. <https://doi.org/10.1049/iet-map.2009.0049>.

Krishnaswamy, Haribabu, Sivaprakash Muthukrishnan, Sathish Thanikodi, Godwin Arockiaraj Antony, and Vijayan Venkatraman. 2020. "Investigation of Air Conditioning Temperature Variation by Modifying the Structure of Passenger Car Using Computational Fluid Dynamics." *Thermal Science* 24 (1 Part B): 495–98.

Kumar, Arvind, and Mithilesh Kumar. 2014. "Gain Enhancement in a Novel Square Microstrip Patch Antenna Using Metallic Rings." *International Conference on Recent Advances and Innovations in Engineering (ICRAIE-2014)*. <https://doi.org/10.1109/icraie.2014.6909168>.

Li, Hui, Sining Sun, and Baoyi Wang. 2018. "Design of Wearable Dual-Antenna System Based on Theory of Characteristic Mode." *2018 IEEE International Symposium on Antennas and Propagation & USNC/URSI National Radio Science Meeting*. <https://doi.org/10.1109/apusncursinrsm.2018.8608997>.

Malli Sureshbabu, Nivedhitha, Kathiravan Selvarasu, Jayanth Kumar V, Mahalakshmi Nandakumar, and Deepak Selvam. 2019. "Concentrated Growth Factors as an Ingenious Biomaterial in Regeneration of Bony Defects after Periapical Surgery: A Report of Two Cases." *Case Reports in Dentistry* 2019 (January): 7046203.

Mathew, M.G., S.R. Samuel, A.J. Soni, and K.B. Roopa. 2020. "Evaluation of Adhesion of Streptococcus Mutans, Plaque Accumulation on Zirconia and Stainless Steel Crowns, and Surrounding Gingival Inflammation in Primary" *Clinical Oral Investigations*. <https://link.springer.com/article/10.1007/s00784-020-03204-9>.

Mehta, Meenu, Deeksha, Devesh Tewari, Gaurav Gupta, Rajendra Awasthi, Harjeet Singh, Parijat Pandey, et al. 2019. "Oligonucleotide Therapy: An Emerging Focus Area for Drug Delivery in Chronic Inflammatory Respiratory Diseases." *Chemico-Biological Interactions* 308 (August): 206–15.

Mishra, Raj Gaurav, Ranjan Mishra, and Piyush Kuchhal. 2018. "Design and Analysis of a Wide Band Rectangular Slot Loaded Planer Microstrip Antenna." *International Journal of Engineering & Technology*. <https://doi.org/10.14419/ijet.v7i2.8.10480>.

Mishra, R., P. Kuchhal, and A. Kumar. 2015. "Effect of Height of the Substrate and Width of the Patch on the Performance Characteristics of Microstrip Antenna." *International Journal of Electrical and Computer Engineering (IJECE)*. <https://doi.org/10.11591/ijece.v5i6.pp1441-1445>.

Muthukrishnan, Sivaprakash, Haribabu Krishnaswamy, Sathish Thanikodi, Dinesh Sundaresan, and Vijayan Venkatraman. 2020. "Support Vector Machine for Modelling and Simulation of Heat Exchangers." *Thermal Science* 24 (1 Part B): 499–503.

- Nguyen, Thanh Huong, Thi Lan Huong Nguyen, and Tan Phu Vuong. 2019. "A Printed Wearable Dual Band Antenna for Remote Healthcare Monitoring Device." *2019 IEEE-RIVF International Conference on Computing and Communication Technologies (RIVF)*. <https://doi.org/10.1109/rivf.2019.8713714>.
- Pc, J., T. Marimuthu, and P. Devadoss. 2018. "Prevalence and Measurement of Anterior Loop of the Mandibular Canal Using CBCT: A Cross Sectional Study." *Clinical Implant Dentistry and Related Research*. <https://europepmc.org/article/med/29624863>.
- Qin, Fan, Steven Shichang Gao, Qi Luo, Chun-Xu Mao, Chao Gu, Gao Wei, Jiadong Xu, et al. 2016. "A Simple Low-Cost Shared-Aperture Dual-Band Dual-Polarized High-Gain Antenna for Synthetic Aperture Radars." *IEEE Transactions on Antennas and Propagation*. <https://doi.org/10.1109/tap.2016.2559526>.
- Rachmansyah, Rachmansyah, Antonius Irianto, and A. Benny Mutiara. 2011. "Designing and Manufacturing Microstrip Antenna for Wireless Communication at 2.4 GHz." *International Journal of Computer and Electrical Engineering*. <https://doi.org/10.7763/ijcee.2011.v3.401>.
- Rahmatian, Pegah, Masoud Movahhedi, and Ali Ghafoorzadeh- Yazdi. 2018. "Dual-Band Dual-Mode Wearable Antenna for On-Off Body Communication Based on Metamaterial." *Electrical Engineering (ICEE), Iranian Conference on*. <https://doi.org/10.1109/icee.2018.8472524>.
- Ramadurai, Neeraja, Deepa Gurunathan, A. Victor Samuel, Emg Subramanian, and Steven J. L. Rodrigues. 2019. "Effectiveness of 2% Articaine as an Anesthetic Agent in Children: Randomized Controlled Trial." *Clinical Oral Investigations* 23 (9): 3543–50.
- Ramesh, Asha, Sheeja Varghese, Nadathur D. Jayakumar, and Sankari Malaiappan. 2018. "Comparative Estimation of Sulfiredoxin Levels between Chronic Periodontitis and Healthy Patients - A Case-Control Study." *Journal of Periodontology* 89 (10): 1241–48.
- Roy, Atser A., Joseph M. Mom, and Douglas T. Kureve. 2013. "Effect of Dielectric Constant on the Design of Rectangular Microstrip Antenna." *2013 IEEE International Conference on Emerging & Sustainable Technologies for Power & ICT in a Developing Society (NIGERCON)*. <https://doi.org/10.1109/nigercon.2013.6715645>.
- Samuel, Melvin S., Jayanta Bhattacharya, Sankalp Raj, Needhidasan Santhanam, Hemant Singh, and N. D. Pradeep Singh. 2019. "Efficient Removal of Chromium(VI) from Aqueous Solution Using Chitosan Grafted Graphene Oxide (CS-GO) Nanocomposite." *International Journal of Biological Macromolecules* 121 (January): 285–92.
- Samuel, Srinivasan Raj, Shashidhar Acharya, and Jeevika Chandrasekar Rao. 2020. "School Interventions-Based Prevention of Early-Childhood Caries among 3-5-Year-Old Children from Very Low Socioeconomic Status: Two-Year Randomized Trial." *Journal of Public Health Dentistry* 80 (1): 51–60.
- Sathish, T., and S. Karthick. 2020. "Wear Behaviour Analysis on Aluminium Alloy 7050 with Reinforced SiC through Taguchi Approach." *Journal of Japan Research Institute for Advanced Copper-Base Materials and Technologies* 9 (3): 3481–87.
- Sharma, Parvarish, Meenu Mehta, Daljeet Singh Dhanjal, Simran Kaur, Gaurav Gupta, Harjeet Singh, Lakshmi Thangavelu, et al. 2019. "Emerging Trends in the Novel Drug Delivery Approaches for the Treatment of Lung Cancer." *Chemico-Biological Interactions* 309 (August): 108720.
- Sridharan, Gokul, Pratibha Ramani, Sangeeta Patankar, and Rajagopalan Vijayaraghavan. 2019. "Evaluation of Salivary Metabolomics in Oral Leukoplakia and Oral Squamous Cell Carcinoma."

Journal of Oral Pathology & Medicine: Official Publication of the International Association of Oral Pathologists and the American Academy of Oral Pathology 48 (4): 299–306.

Varghese, Sheeja Saji, Asha Ramesh, and Deepak Nallaswamy Veeraiyan. 2019. “Blended Module-Based Teaching in Biostatistics and Research Methodology: A Retrospective Study with Postgraduate Dental Students.” *Journal of Dental Education* 83 (4): 445–50.

Venu, Harish, V. Dhana Raju, and Lingesan Subramani. 2019. “Combined Effect of Influence of Nano Additives, Combustion Chamber Geometry and Injection Timing in a DI Diesel Engine Fuelled with Ternary (diesel-Biodiesel-Ethanol) Blends.” *Energy* 174 (May): 386–406.

Venu, Harish, Lingesan Subramani, and V. Dhana Raju. 2019. “Emission Reduction in a DI Diesel Engine Using Exhaust Gas Recirculation (EGR) of Palm Biodiesel Blended with TiO₂ Nano Additives.” *Renewable Energy* 140 (September): 245–63.

Verma, Anju, Debajit De, S. Nanda, A. Tripathy, and P.K. Sahu. 2016. “Design of a Dual Band Rectangular Microstrip Patch Antenna with DGS for Wireless Applications.” *2016 3rd International Conference on Signal Processing and Integrated Networks (SPIN)*.
<https://doi.org/10.1109/spin.2016.7566670>.

Vignesh, R., Ditto Sharmin, C. Vishnu Rekha, Sankar Annamalai, and Parisa Norouzi Baghkomeh. 2019. “Management of Complicated Crown-Root Fracture by Extra-Oral Fragment Reattachment and Intentional Reimplantation with 2 Years Review.” *Contemporary Clinical Dentistry* 10 (2): 397–401.

Vijayakumar Jain, S., M.R. Muthusekhar, M.F. Baig, P. Senthilnathan, S. Loganathan, P.U. Abdul Wahab, M. Madhulakshmi, and Yogaen Vohra. 2019. “Evaluation of Three-Dimensional Changes in Pharyngeal Airway Following Isolated Lefort One Osteotomy for the Correction of Vertical Maxillary Excess: A Prospective Study.” *Journal of Maxillofacial and Oral Surgery* 18 (1): 139–46.

Vijayashree Priyadharsini, Jayaseelan. 2019. “In Silico Validation of the Non-Antibiotic Drugs Acetaminophen and Ibuprofen as Antibacterial Agents against Red Complex Pathogens.” *Journal of Periodontology* 90 (12): 1441–48.

Yadav, Manojkumar Brijlal, Bharti Singh, and Vidyadhar S. Melkeri. 2017. “Design of Rectangular Microstrip Patch Antenna with DGS at 2.45 GHz.” *2017 International Conference of Electronics, Communication and Aerospace Technology (ICECA)*. <https://doi.org/10.1109/iceca.2017.8203706>.

Zheng, Yuejun, Jun Gao, Yulong Zhou, Xiangyu Cao, Huanhuan Yang, Sijia Li, and Tong Li. 2018. “Wideband Gain Enhancement and RCS Reduction of Fabry–Perot Resonator Antenna With Chessboard Arranged Metamaterial Superstrate.” *IEEE Transactions on Antennas and Propagation*.
<https://doi.org/10.1109/tap.2017.2780896>